

Instruction Manual



PHOENIX MODEL®

GP
version

EP
version



T-6 TEXAN II

GP/EP SCALE 1:7 ARF .46-.55

SPECIFICATION

- **Wingspan:** 1490mm (58.6in)
- **Length:** 1270mm (50in)
- **Flying weight:** 3200gr-3400gr
- **Wing area:** 39dm²
- **Wing loading:** 82g/dm²
- **Wing type:** Naca airfoils
- **Covering type:** Genuine ORACOVER®
- **Gear type:** Retract and CNC strut gear (included)
- **Spinner size:** Plastic 58mm (included)
- **Radio:** 6 channel minimum (not included)
- **Servo:** 6 standard servo: 2 aileron; 1 elevator; 1 rudder; 1 steering nose; 1 throttle; 2 servo retract futaba S3170G (not included)
- **Recommended receiver battery:** 4.8-6V / 800-1200mAh NiMH (not included)
- **Servo mount:** 21mm x 42 mm
- **Propeller:** suit with your engine
- **Engine:** .46-.55 / 2-stroke or .52/4-stroke glow engine (not included)
- **Motor:** brushless outrunner 1000-1400 W, 480 KV (not included)
- **Gravity CG:** 90-100 mm (3.5-3.9 in) Back from the leading edge of the wing, at the fuselage
- **Control throw Ailerons:** Low: 8mm up/down, 10% expo; High: 10mm up/down, 10% expo
- **Control throw Elevators:** Low: 8mm up/down, 12% expo; High: 10mm up/down, 12% expo
- **Control throw Rudder:** Low: 25mm right/left, 15% expo; High: 40mm right/left, 15% expo
- **Experience level:** Intermediate
- **Plane type:** Scale Military

RECOMMENDED MOTOR AND BATTERY SET UP

- **Motor:** RIMFIRE .46-.55 (not included)
- **Lipo cell:** 4-6 cells / 4000 – 5500mAh (not included)
- **Esc:** 50-80A (not included)

TOOLS AND SUPPLIES NEEDED.

- Medium C/A glue
- 30 minute epoxy
- 6 minute epoxy
- Hand or electric drill
- Assorted drill bits
- Modeling knife
- Straight edge ruler
- 2 bender plier
- Wire cutters
- Masking tape
- Thread lock
- Paper towels
- Rubbing alcohol

SUGGESTION

To avoid scratching your new airplane, do not unwrap the pieces until they are needed for assembly. Cover your workbench with an old towel or brown paper, both to protect the aircraft and to protect the table. Keep a couple of jars or bowls handy to hold the small parts after you open the bag.

NOTE:

Please trial fit all the parts. Make sure you have the correct parts and that they fit and are aligned properly before gluing! This will assure proper assembly. The T-6 TEXAN II GP/EP SCALE 1:7 ARF .46-.55 is hand made from natural materials, every plane is unique and minor adjustments may have to be made. However, you should find the fit superior and assembly simple.

The painted and plastic parts used in this kit are fuel proof. However, they are not tolerant of many harsh chemicals including the following: paint thinner, C/A glue accelerator, C/A glue debonder and acetone. Do not let these chemicals come in contact with the colors on the covering and the plastic parts.

SAFETY PRECAUTION:

- This is not a toy
- Be sure that no other flyers are using your radio frequency.
- Do not smoke near fuel
- Store fuel in a cool, dry place, away from children and pets.
- Wear safety glasses.
- The glow plug clip must be securely attached to the glow plug.
- Do not flip the propeller with your fingers.
- Keep loose clothing and wires away from the propeller.
- Do not start the engine if people are near. Do not stand in line with the side of the propeller.
- Make engine adjustments from behind the propeller only. Do not reach around the spinning propeller.

PREPARATIONS

Use a covering iron with a covering sock on high heat to tighten the covering if necessary. Apply pressure over sheeted areas to thoroughly bond the covering to the wood.

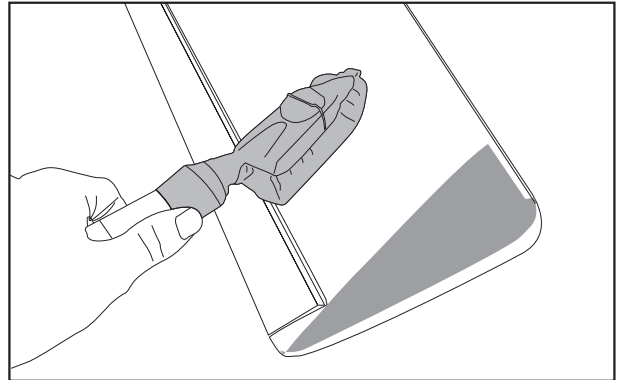
**INSTALLING THE AILERONS**

1. Test fit the ailerons to the wing with the hinges. If the hinges don't remain centered, stick a pin through the middle of the hinge to hold it in position.

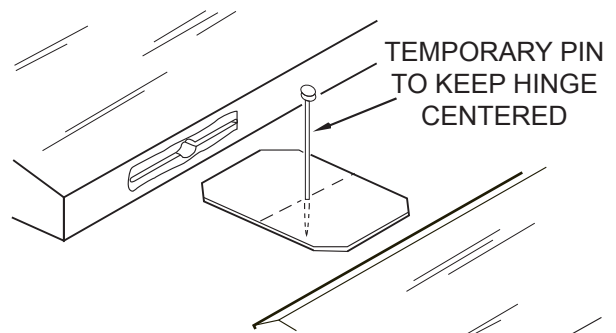

2. Apply six drops of thin CA to the top and bottom of each hinge. Do not use CA accelerator. After the CA has fully hardened, test the hinges by pulling on the aileron.

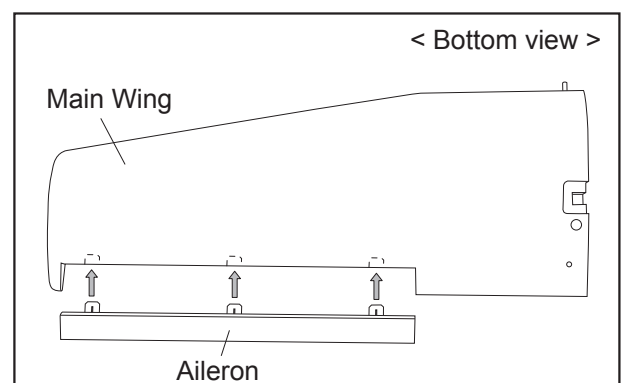

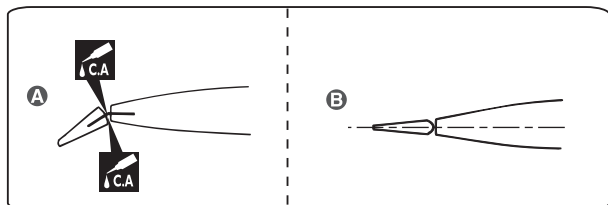

CA Apply instant glue (CA glue, super glue).



► Make certain the hinges are adequately secured with glue. If they come loose in flight accidents may result.

- A** Secure nylon hinges with instant glue, being careful not to glue the wing and aileron together.
- B** Align the center line of main wing with aileron.

INSTALLING THE AILERON SERVOS

1. Install the rubber grommets and brass eyelets onto the aileron servo.
2. Using a modeling knife, remove the covering from over the pre-cut servo arm exit hole on the aileron servo tray / hatch. This hole will allow the servo arm to pass through when installing the aileron pushrods.
3. Place the servo into the servo tray. Center the servo within the tray and drill pilot holes through the block of wood for each of the four mounting screws provided with the servo.

4. Using the thread as a guide and using masking tape, tape the servo lead to the end of the thread: carefully pull the thread out. When you have pulled the servo lead out, remove the masking tape and the servo lead from the thread.
5. Place the aileron servo tray / hatch into the servo box on the bottom of the wing and drill pilot holes through the tray and the servo box for each of the four mounting screws. Secure the servo tray in place using the mounting screws provided .
6. Repeat step # 2 - # 5 to install the second aileron servo in the opposite wing half.

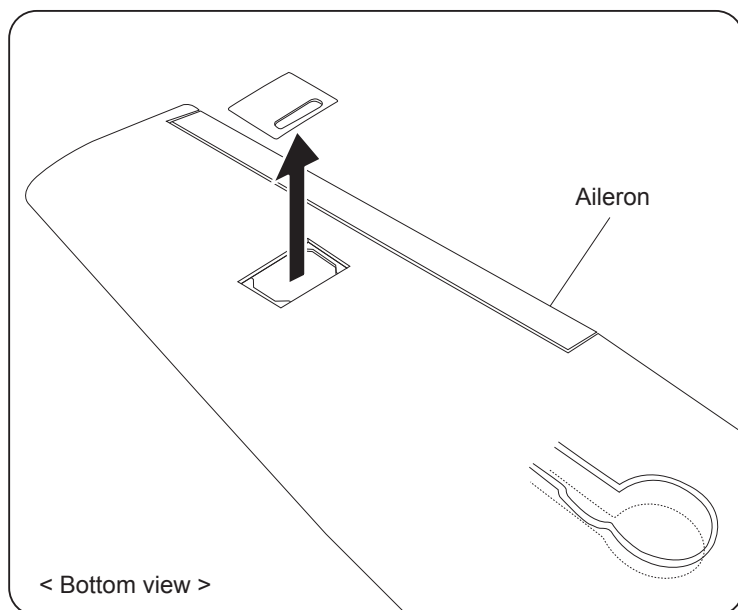

- A** Cut away film only. here
- B** Supplied with the servo
- X** Must be purchased separately!
- L/R** Assemble left and right sides the same way

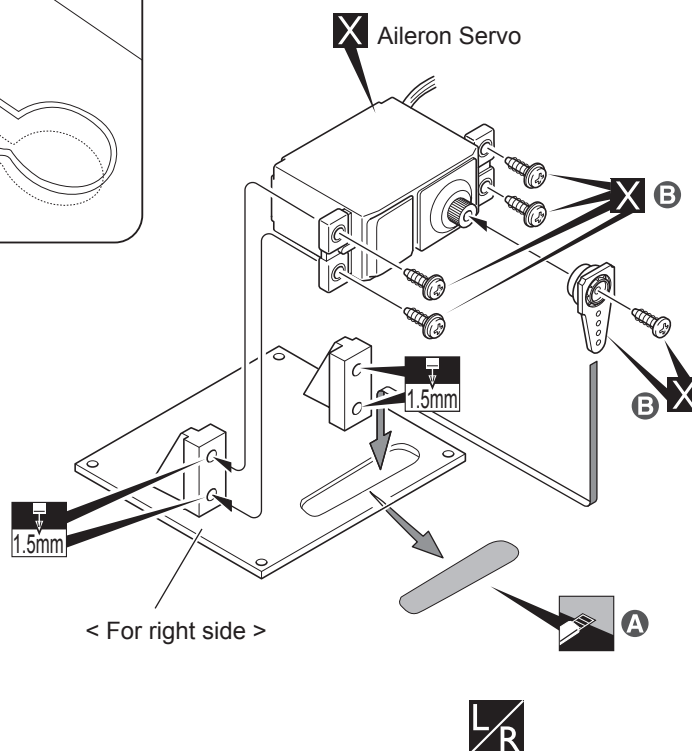
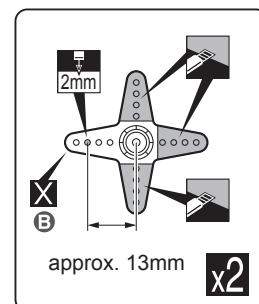
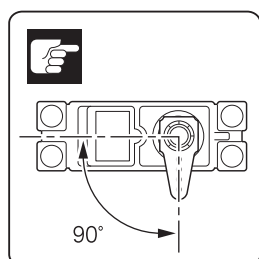

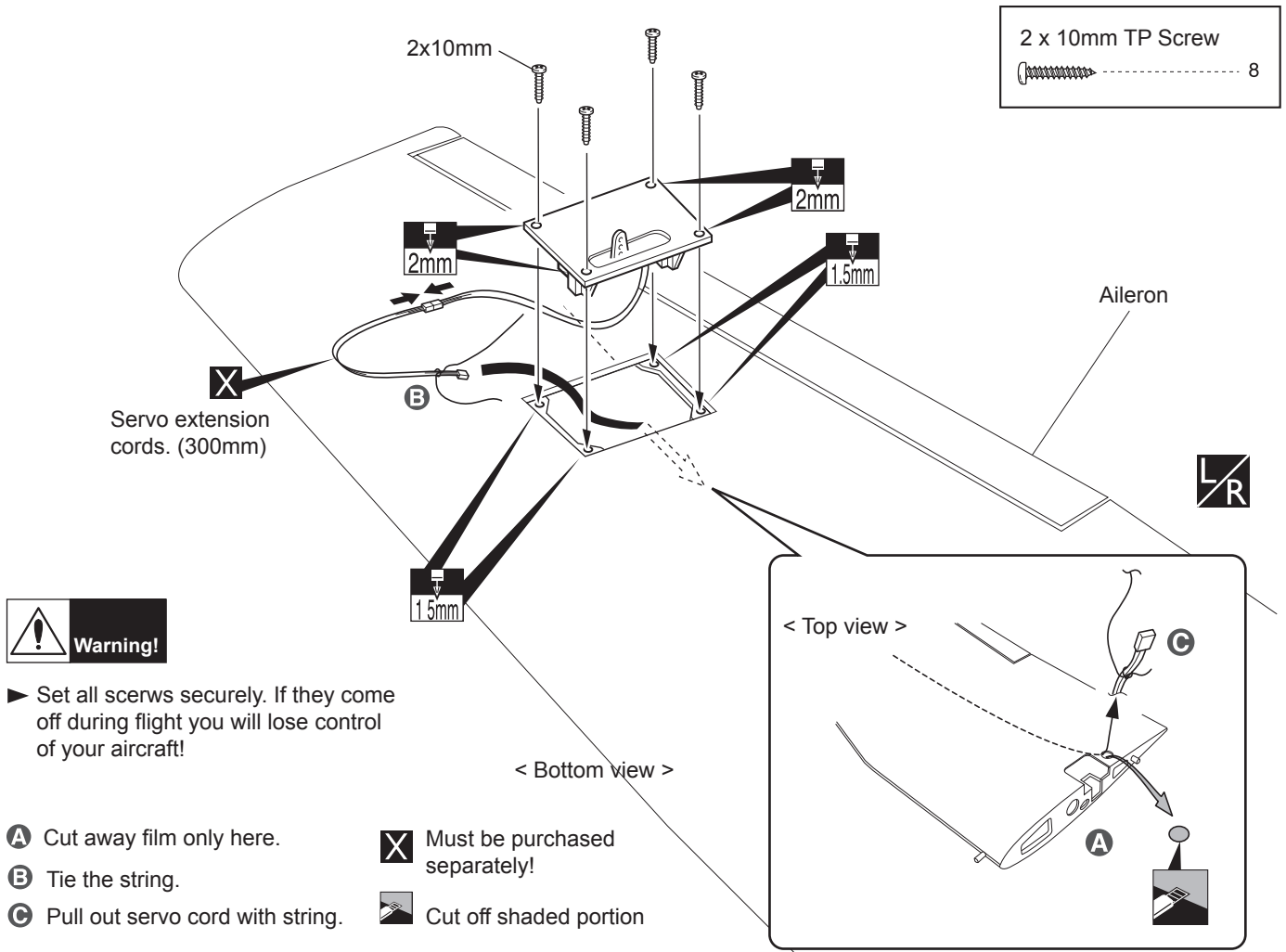

▶ Set all screws securely. If they come off during flight you will lose control of your aircraft!

- A Cut away film only here.
- B Tie the string.
- C Pull out servo cord with string.
- X Must be purchased separately!
- [Shaded box icon] Cut off shaded portion

INSTALLING THE CONTROL HORNS

1. One aileron control horn in positioned on each aileron. Using a ruler and a pen, locate and mark the location of the control horn. It should be mounted on the bottom side of the aileron at the leading edge, IN LINE with the aileron pushrod.
2. Drill two holes through the aileron using the control horn as a guide and screw the control horn in place.

3. Repeat step # 1 - # 2 to install the control horn on the opposite aileron.

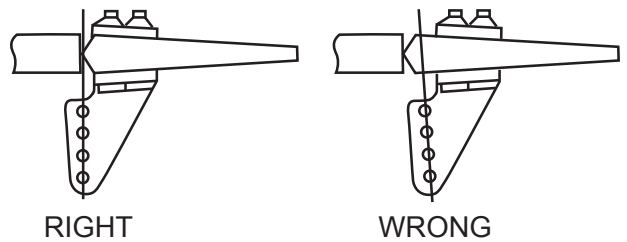

INSTALLING THE AILERON LINKAGES

1. Working with the aileron linkage for now, thread one nylon clevis at least 14 turns onto one of the 2mm x 180mm threaded wires.
2. Attach the clevis to the outer hole in the control horn. Install a silicone tube on the clevis.
3. Locate one nylon servo arm, and using wire cutters, remove all but one of the arms. Using a 2mm drill bit, enlarge the third hole out from the center of the arm to accommodate the aileron pushrod wire.
4. Plug the aileron servo into the receiver and center the servo. Install the servo arm onto the servo. The servo arm should be perpendicular to the servo and point toward the middle of the wing.
5. Center the aileron and hold it in place using a couple of pieces of masking tape.

6. With the aileron and aileron servo centered, carefully place a mark on the aileron pushrod wire where it crosses the hole in the servo arm.
7. Using pliers, carefully make a 90 degree bend down at the mark made. Cut off the excess wire, leaving about 6mm beyond the bend.
8. Insert the 90 degree bend down through the hole in the servo arm. Install one nylon snap keeper over the wire to secure it to the arm. Install the servo arm retaining screw and remove the masking tape from the aileron.
9. Repeat step # 4 - # 8 to install the second aileron linkage. After both linkages are completed, connect both of the aileron servo leads using a Y-harness you have purchased separately.

2 x 20mm TP Screw



----- 4

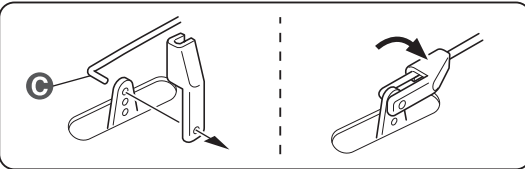

C Bend 90°

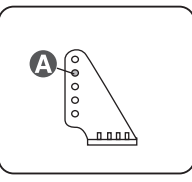

A Use this hole.

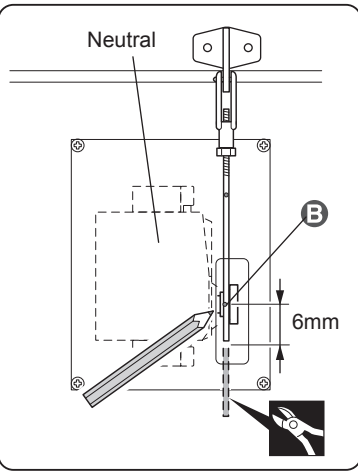

B Mark the spot to attach.

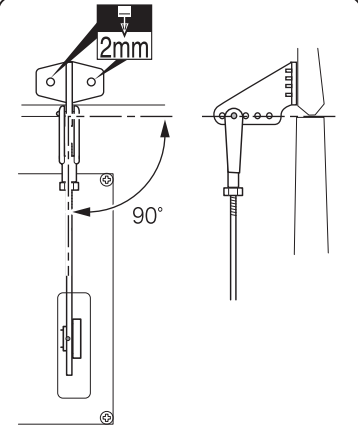

2mm
90°

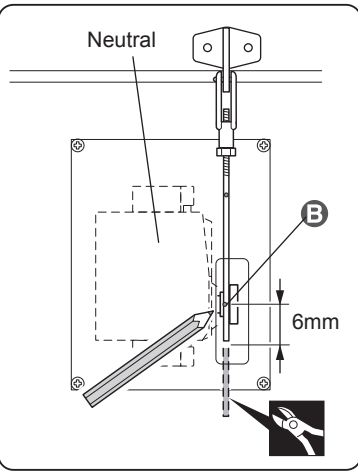

6mm

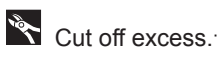

Cut off excess.



L/R

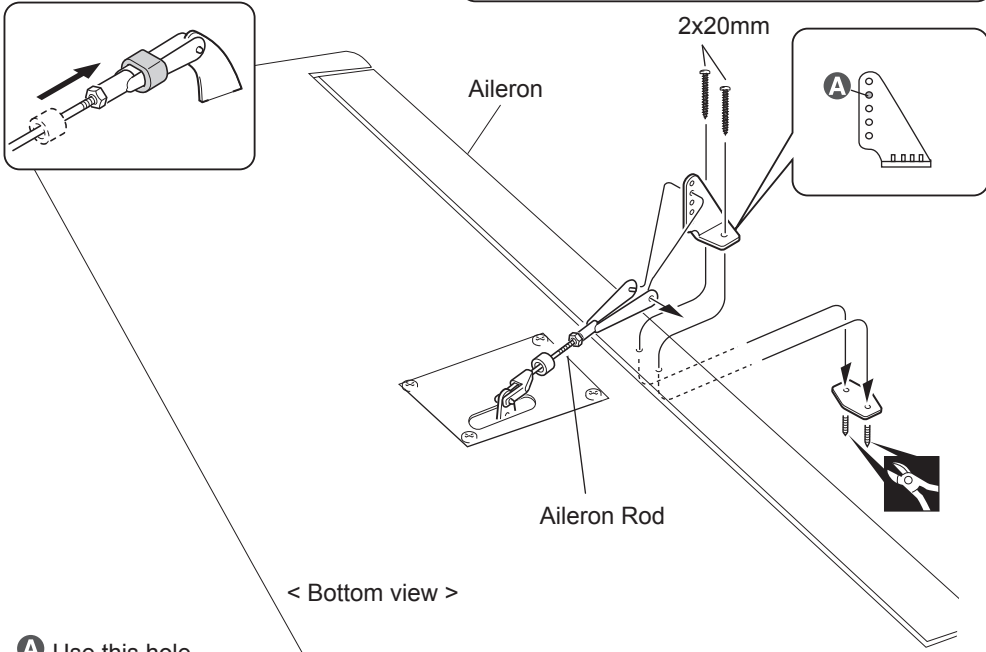

Aileron
Aileron Rod
2x20mm

< Bottom view >

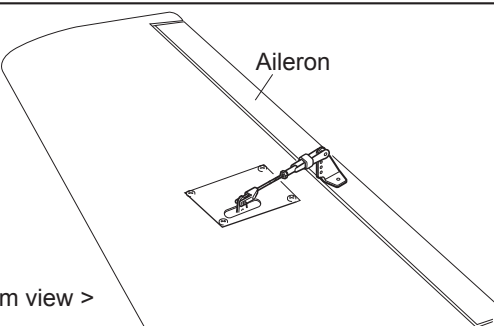

Aileron

< Bottom view >

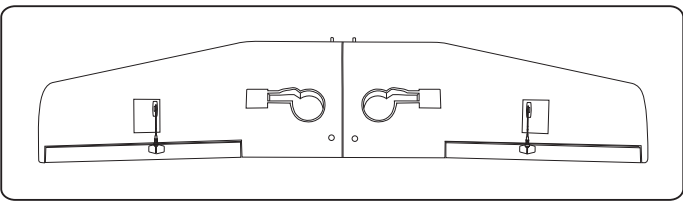



L/R

INSTALLING THE MAIN LANDING GEAR

3 x 8mm Button Screw



----- 8

5 x 45mm Cap Screw

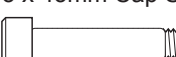

----- 2

5mm Collar



----- 2

4x4mm Set Screw



----- 2

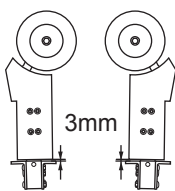

3mm

< Main Gear (L) > < Main Gear (R) >

< Main Gear (R) >

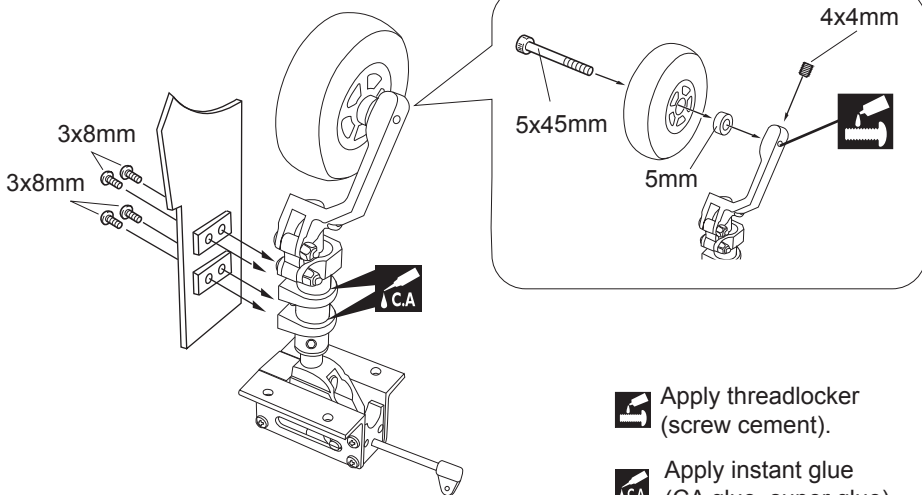

3x8mm
3x8mm
4x4mm
5x45mm
5mm
C.A.



Apply threadlocker (screw cement).



Apply instant glue (CA glue, super glue).



Pay close attention here!

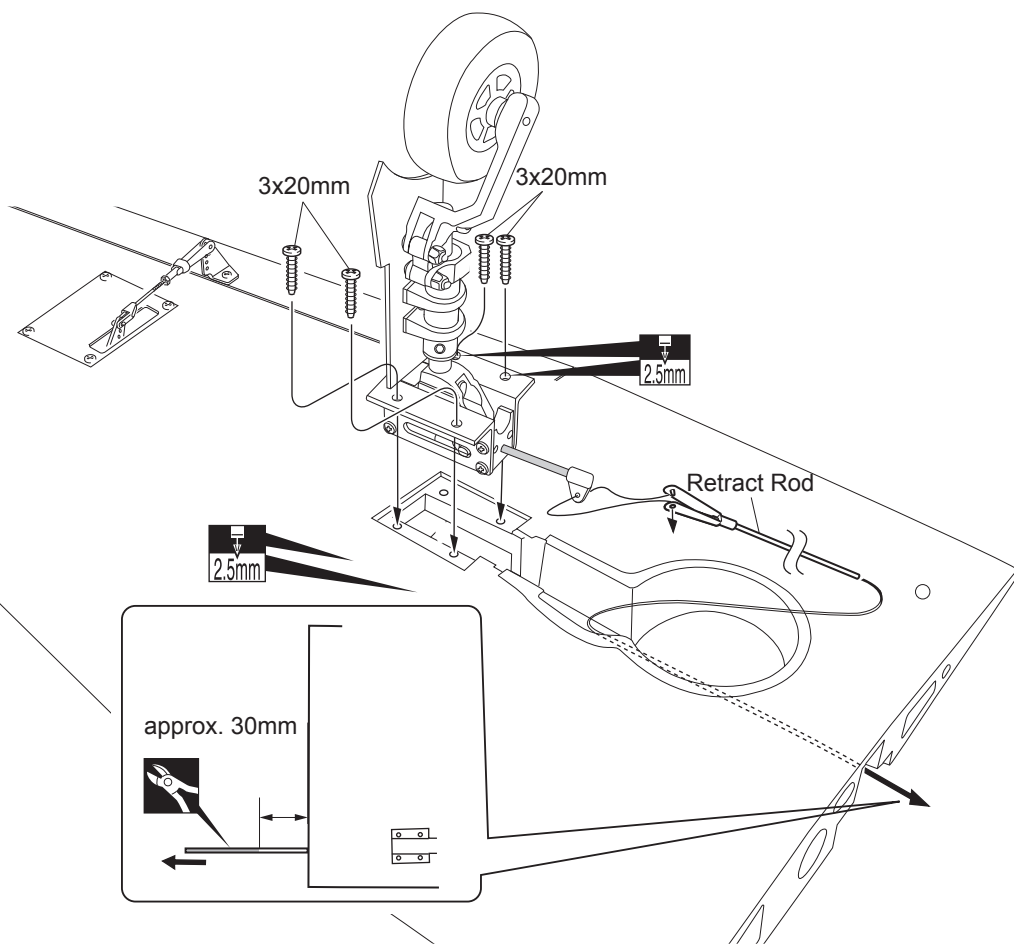
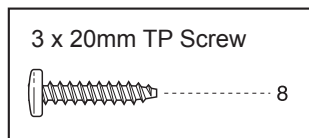
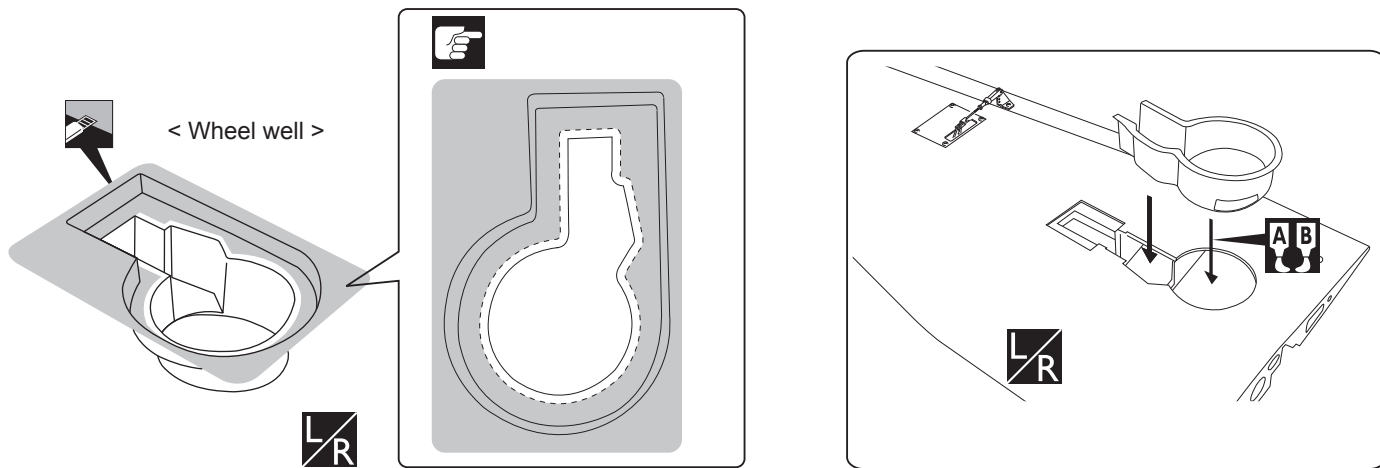

- Cut off shaded portion
- Apply epoxy glue
- Cut off excess.

WING ASSEMBLY

Note We highly recommend using 30 Minute Epoxy over faster curing epoxies for several reasons. First, slower curing epoxy is stronger. It also provides more working time, allowing the builder to properly align the parts. Using fast cure epoxy when joining the wing halves could result in the glue drying before the wing halves are aligned properly, causing damage to the wing assembly. Also, when joining the wing halves, the entire area of both center ribs need to be joined completely with no gaps existing. Not following these steps carefully, may result in failure of the wing center section during flight.

- 1) Locate the wing dihedral brace. Using a ruler, locate its center and place a mark. Draw a vertical line at the mark just made .
- 2) Test fit the dihedral brace into each wing half. The brace should slide in easily up to the centerline you drew. If it does not, use 220 grit sandpaper with a sanding block and sand down the edges and ends of the brace until the proper fit is obtained.
- 3) When satisfied with the fit of the dihedral brace in each wing half, remove the brace .Mix equal amounts of part A and part B 30 minute epoxy. Coat all sides of the dihedral brace box and half of the wing brace with the epoxy. Make sure to cover the top and bottom as well as the sides. Use enough epoxy to fill any gaps.

4) Insert the dihedral brace into one wing half up to the centerline. Wipe off any excess epoxy that may have squeezed out of the joint using paper towels.



5) Once the epoxy has cured, trial fit both wing halves together. The center gibs should fit flush together with little or no gaps existing. If gaps do exist, use 220 Grit sandpaper and sand down the high spots on the root ribs and the wing joiner until the proper fit is obtained.

6) To protect the covering from the epoxy used to glue the wing halves together, carefully apply masking tape around the edge of the root rib on the top and bottom of each wing half.

7) Mix a generous amount of 30 minute epoxy. Coat the exposed half of the dihedral brace, the wing joiner box and both root ribs with epoxy. Slide the two wing halves together and carefully align them at the leading and trailing edges. Wipe away any excess epoxy using paper towels. Use masking tape wrapped around the center section to hold the halves in place until the epoxy cures.

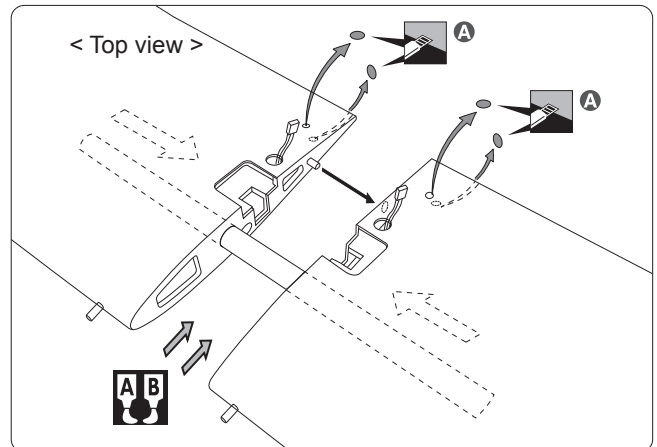
8) When the epoxy has cured, carefully remove the masking tape from the wing.



-  Apply epoxy glue
-  Cut off shaded portion

INSTALLING THE RETRACT SERVO MAIN

LANDING GEAR

1. Install the adjustable servo connector to the servo arm of the servo retract gear.
2. Install the servo retract to the wing.

- | | |
|-------------------|---|
| 4 x 4mm Set Screw | 2 |
| Linkage Stopper | 2 |
| 2mm Nut | 4 |
| 2 x 10mm Screw | 2 |

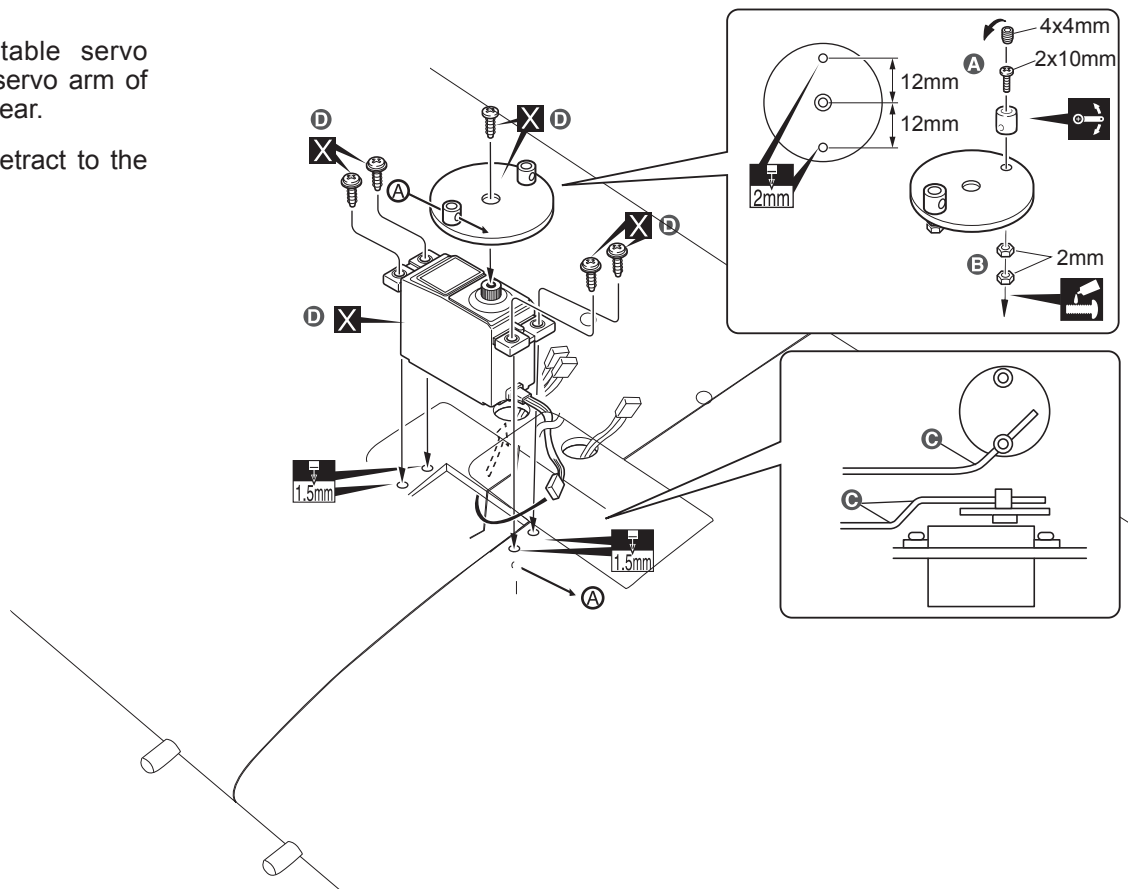

-  Temporarily remove
-  Tighten the 2 nuts properly
-  Bend the linkage rod
-  Supplied with the servo
-  Apply threadlocker (screw cement).
-  Must be purchased separately!
-  Ensure smooth, non-binding movement when assembling



► Make sure linkages for landing gear are properly locked.

- A** Cut off excess.
- B** If linkage rods foul, bend accordingly to ensure free movement.

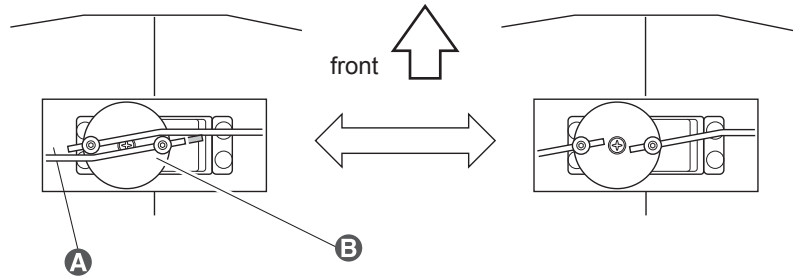

Retract and the gear is opened.

Retract and the gear is closed.

INSTALLING SECURE THE WING TO THE FUSELAGE

Attach the wings to the fuselage and using the nylon thumbscrews to secure the wing panels.

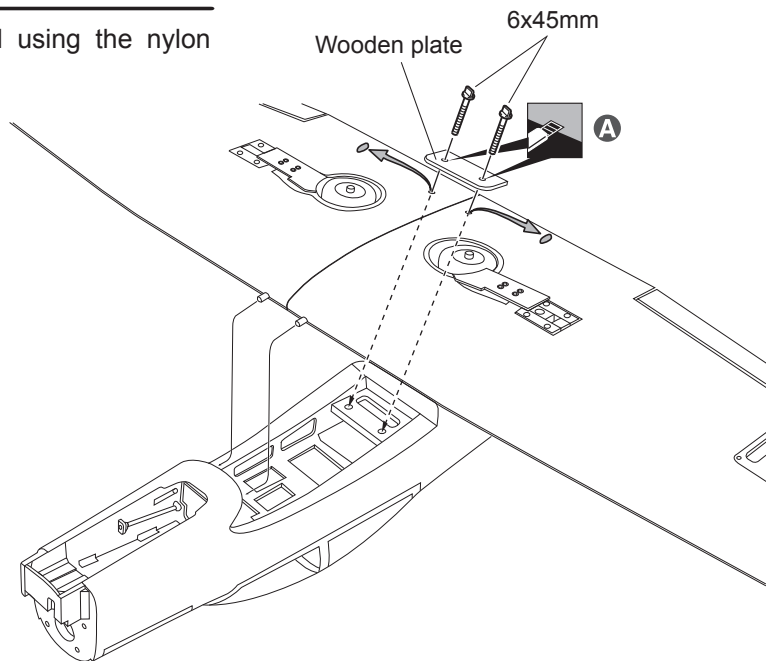
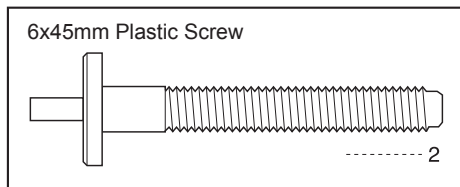

- A** Cut away film only here.



Cut off shaded portion

HORIZONTAL STABILIZER INSTALLATION

1. Using a modeling knife, cut away the covering from the fuselage for the stabilizer and remove it.
2. Draw a center line onto the horizontal stabilizer.
3. Check the fit of the horizontal stabilizer in its slot. Make sure the horizontal stabilizer is square and centered to the fuselage by taking measurements, but don't glue anything yet.
4. With the horizontal stabilizer correctly aligned, mark the shape of the fuselage on the top and bottom of the tail plane using a water soluble / non-permanent felt-tip pen.
5. Remove the stabilizer. Using the lines you just drew as a guide, carefully remove the covering from between them using a modeling knife.
6. When you are sure that everything is aligned correctly, mix up a generous amount of 30 minute epoxy. Apply a thin layer to the top and bottom of the stabilizer mounting area and to the stabilizer mounting platform sides in the fuselage. Slide the stabilizer in place and re-align. Double check all of your measurements one more time before the epoxy cures. Remove any excess epoxy using a paper towel and rubbing alcohol and hold the stabilizer in place with T-pins or masking tape.
7. After the epoxy has fully cured, remove the masking tape or T-pins used to hold the stabilizer in place and carefully inspect the glue joints. Use more epoxy to fill in any gaps that were not filled previously and clean up the excess using a paper towel and rubbing alcohol.
8. Installing the elevator using C.A glue as installing the aileron.



When cutting through the covering to remove it, cut with only enough pressure to only cut through the covering it's self. Cutting into the balsa structure may weaken it. This could lead to possible failure during flight.

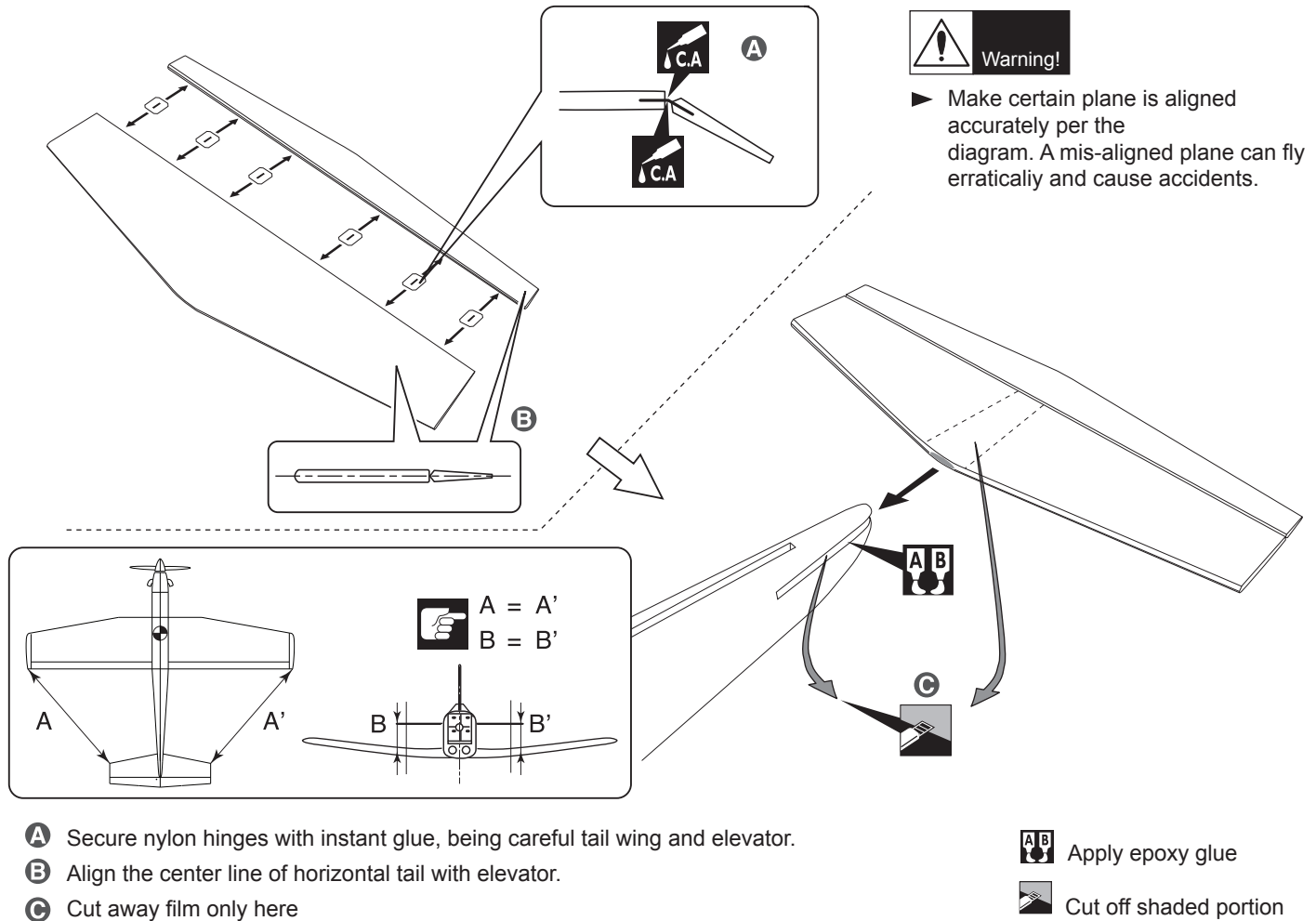

- A** Secure nylon hinges with instant glue, being careful tail wing and elevator.
- B** Align the center line of horizontal tail with elevator.
- C** Cut away film only here

- AB** Apply epoxy glue
- C** Cut off shaded portion

VERTICAL STABILIZER INSTALLATION

1. Using a modeling knife, remove the covering on the top of the fuselage for the vertical stabilizer.
2. Slide the vertical stabilizer into the slot in the mounting platform in the top of the fuselage. Mark the shape of the fuselage on the left and right sides of the vertical stabilizer using a felt-tip pen.
3. Now, remove the vertical stabilizer and using a modeling knife, carefully cut just inside the marked lines and remove the film on both sides of the vertical stabilizer. Just as you did with the horizontal stabilizer, make sure you only press hard enough to cut the film, not the balsa vertical stabilizer.
4. Slide the vertical stabilizer back in place. Using a triangle, check to ensure that the vertical stabilizer is aligned 90 degree to the horizontal stabilizer.
5. When you are sure that everything is aligned correctly, mix up a generous amount of 30 minute epoxy. Apply a thin layer to the slot in the mounting platform and to the vertical stabilizer mounting area. Apply epoxy to the lower rudder hinge. Set the stabilizer in place and re-align. Double check all of your measurements once more before the epoxy cures. Remove any excess epoxy using a paper towel and rubbing alcohol and hold the stabilizer in place with T-pins or masking tape. Allow the epoxy to fully cure before proceeding.

6. Installing the rudder using C.A glue as installing the aileron.

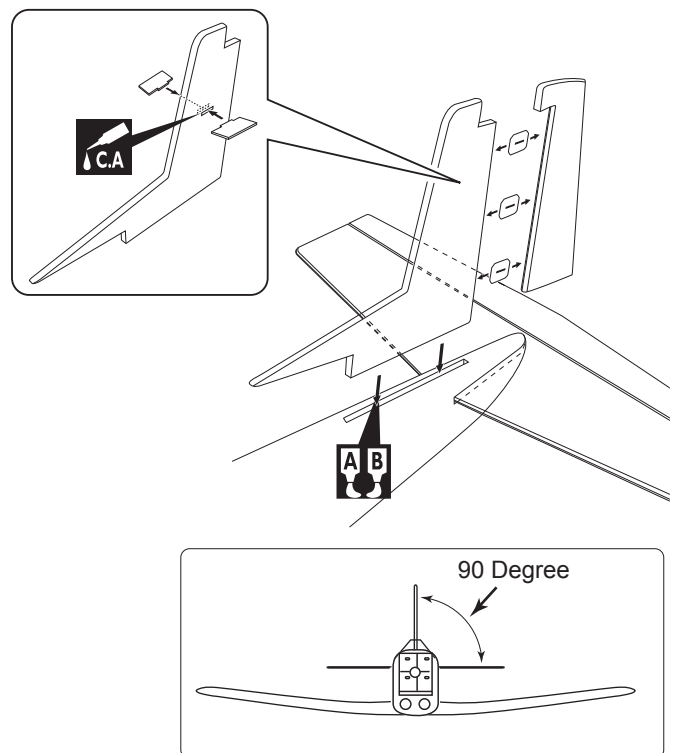

- CA** Apply instant glue (CA glue, super glue).
- AB** Apply epoxy glue
- C** Take off the main wing after put a rudder.

INSTALLING THE RUDDER PUSHROD

1. Locate the pushrod exit slot on the right side of the fuselage.
2. Carefully cut away the covering material from the slot.
3. Working from inside the fuselage, slide the threaded end of the remaining pushrod down the inside of the fuselage until the pushrod reaches the exit slot. Carefully reach in with a small screw driver and guide the pushrod out of the exit slot.
4. Install the clevis on the rudder pushrod. Make sure 6mm of thread shows inside the clevis.
5. The control horn should be mounted on the right side of the rudder at the leading edge, in line with the rudder pushrod.
6. Drill two holes through the rudder using the control horn as a guide and screw the control horn in place.
7. Attach clevis to the third hole in the control horn. Install a silicone tube on the clevis.
8. Locate one nylon servo arm, and using wire cutters, remove all but one of the arms using a 2mm drill bit, enlarge the third hole out from the center to accommodate the rudder pushrod wire.

8. Locate one nylon servo arm, and using wire cutters, remove all but one of the arms using a 2mm drill bit, enlarge the third hole out from the center to accommodate the rudder pushrod wire.
9. Plug the rudder servo into the receiver and center the servo. Install the servo arm onto the servo.
10. Center the rudder and hold it in place using a piece of masking tape.
11. With the rudder and rudder servo centered, carefully place a mark on the rudder pushrod wire where it crosses the hole in the servo arm.
12. Using a pliers, carefully make a 90 degree bend up at the mark made. Cut off excess wire, leaving about 6mm beyond the bend.
13. Insert the 90 degree bend up through the hole in the servo arm. Install one nylon snap keeper over the wire to secure it to the arm. Install the servo arm retaining screw and remove the masking tape from the rudder.
14. Using thick CA glue, secure the pushrod sleeves to the pushrod sleeve guide.

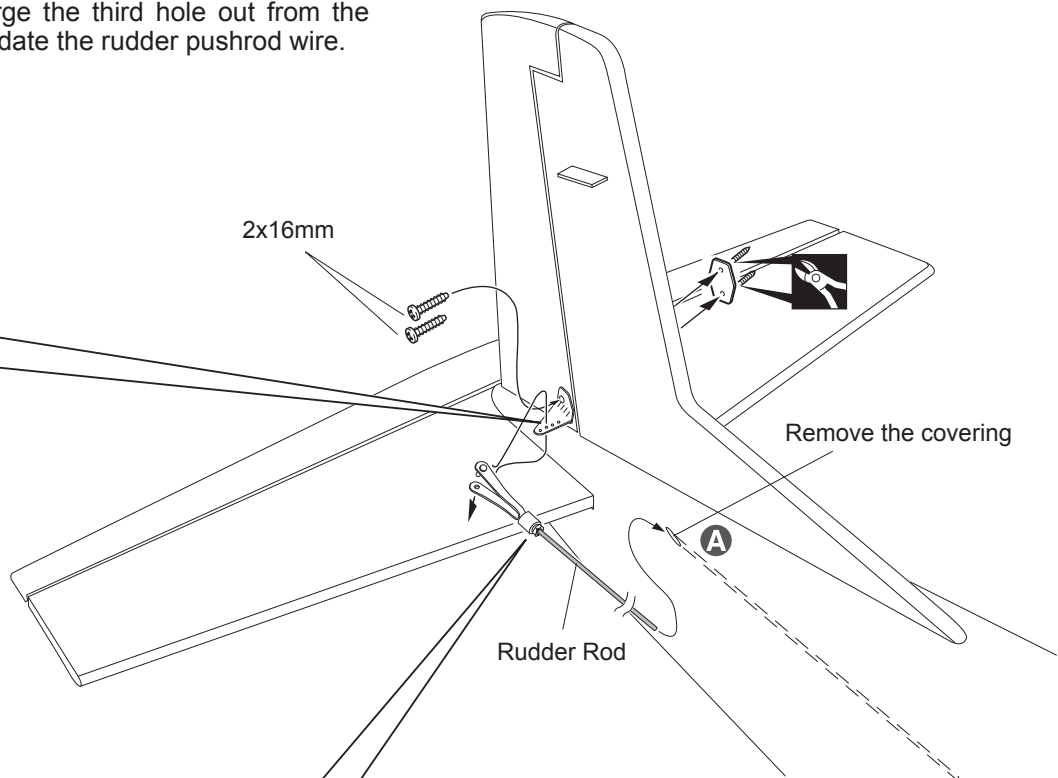
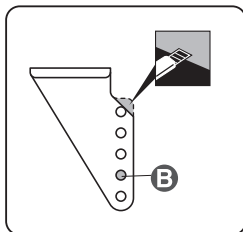
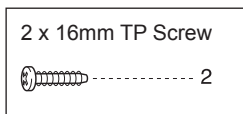

Cut off excess.

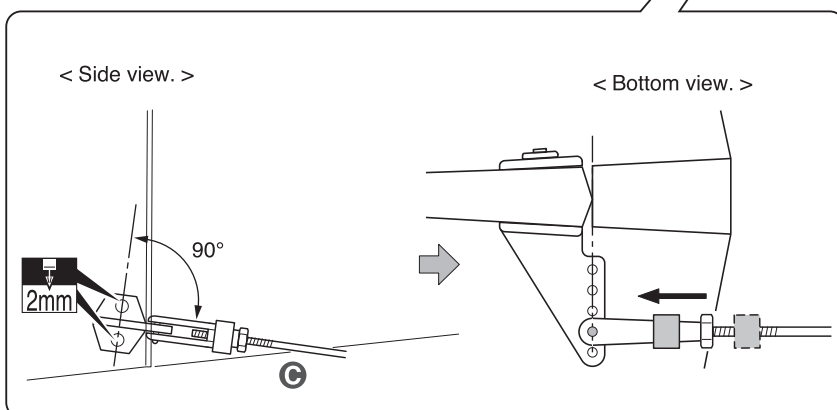

Set all screws securely. If they come off during flight you will lose control of your aircraft!

A Cut away film only here.

B Use this hole

C Install the horn in a position so the rod is straight

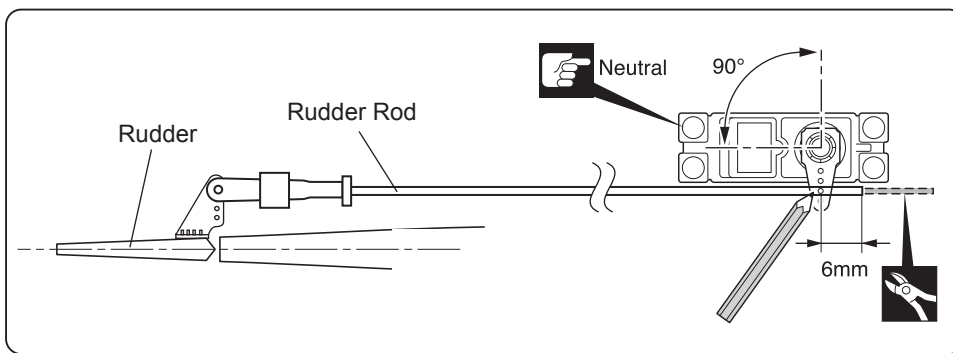
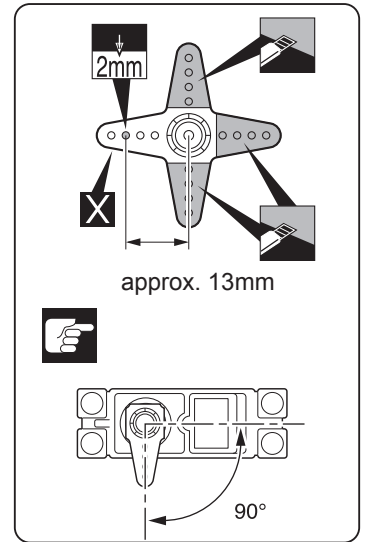
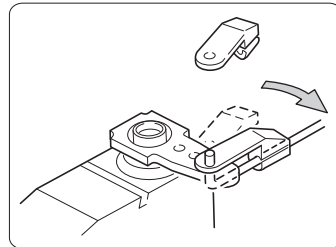
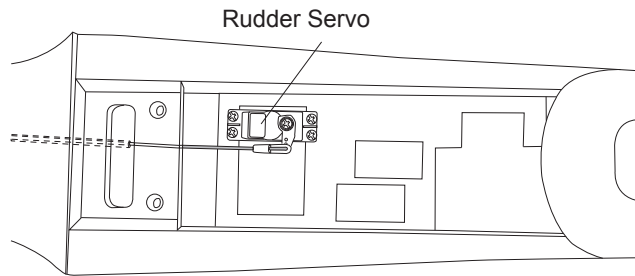
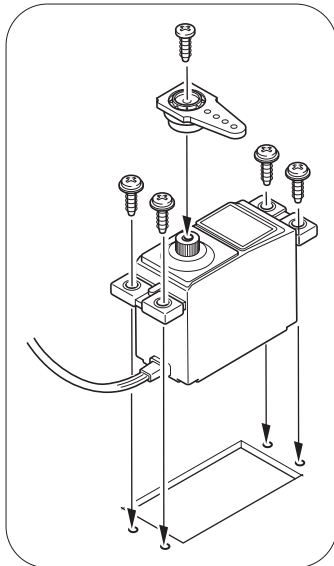

X Must be purchased separately!

Cut off shaded portion

Pay close attention

Cut off excess.



Warning!

Set all screws securely. If they come off during flight you will lose control of your aircraft!

INSTALLING THE ELEVATOR PUSHROD

1. Locate the pushrod exit slot on the left side of the fuselage. It is located slightly ahead and below the horizontal stabilizer.
2. Carefully cut away the covering material from the slot.
3. Working from inside the fuselage, slide the threaded end of the pushrod until it reaches the exit slot. Carefully reach in with a small screw driver and guide the pushrod out of the exit slot.
4. Install the clevis on the elevator pushrod. Make sure 6mm of thread shows inside the clevis.
5. The control horn should be mounted on the bottom, right side of the elevator at the leading edge, in line with the elevator pushrod.
6. Drill two holes through the elevator using the control horn as a guide and screw the control horn in place.
7. Attach clevis to the third hole in the control horn. Install a silicone tube on the clevis.
8. Locate one nylon servo arm, and using wire cutters, remove all but one of the arms. Using a 2mm drill bit, enlarge the third hole out from the center to accommodate the elevator pushrod wire.
9. Plug the elevator servo into the receiver and center the servo. Install the servo arm onto the servo. The servo arm should be perpendicular to the servo and point toward the middle of the fuselage.

10. With the elevator and elevator servo centered, carefully place a mark on the elevator pushrod wire where it crosses the hole in the servo arm.
11. Using pliers, carefully make a 90 degree bend up at the mark made. Cut off the excess wire, leaving about 6mm beyond the bend.
12. Insert the 90 degree bend up through the hole in the servo arm, install one nylon snap keeper over the wire to secure it to the arm. Install the servo arm retaining screw and remove the masking tape the elevator halves.
13. Using thick CA glue, secure the pushrod sleeves to the pushrod sleeve guide.

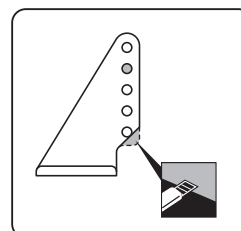

2 x 16mm TP Screw

..... 2

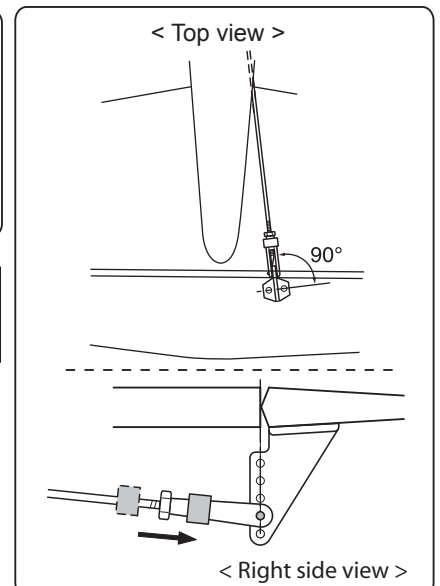

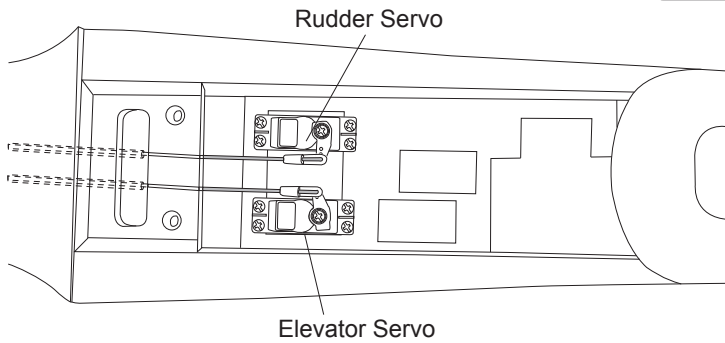
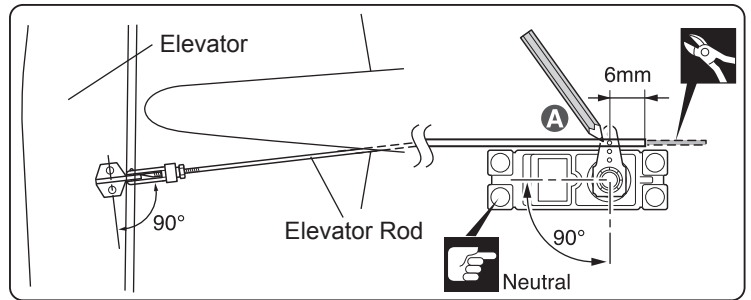
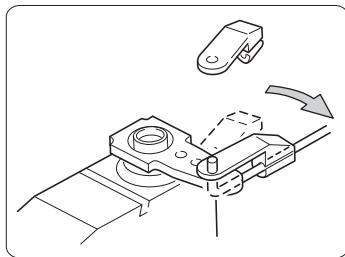
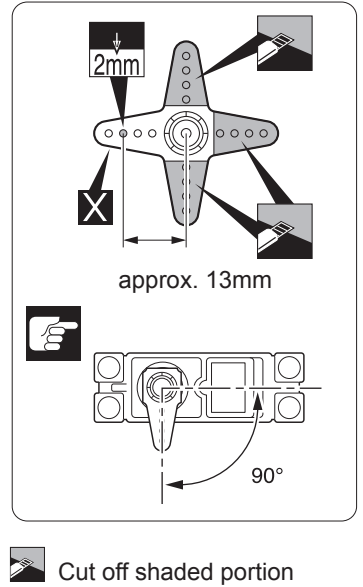
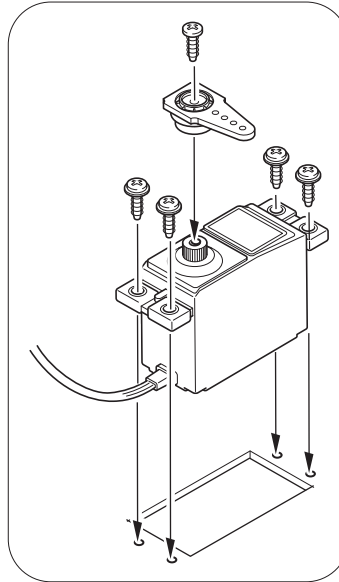
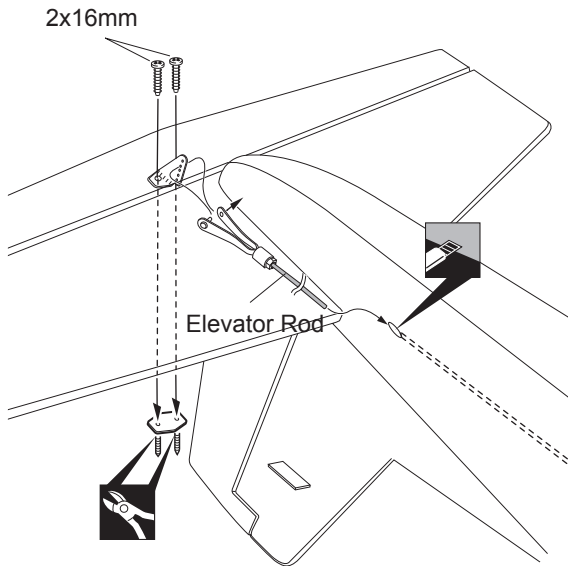

- A** Mark the spot to attach
- B** Install the horn in a position so the rod is straight
- Pay close attention here
- Cut off excess.





Set all screws securely. If they come off during flight you will lose control of your aircraft!

INSTALLING THE NOSE GEAR RETRACT

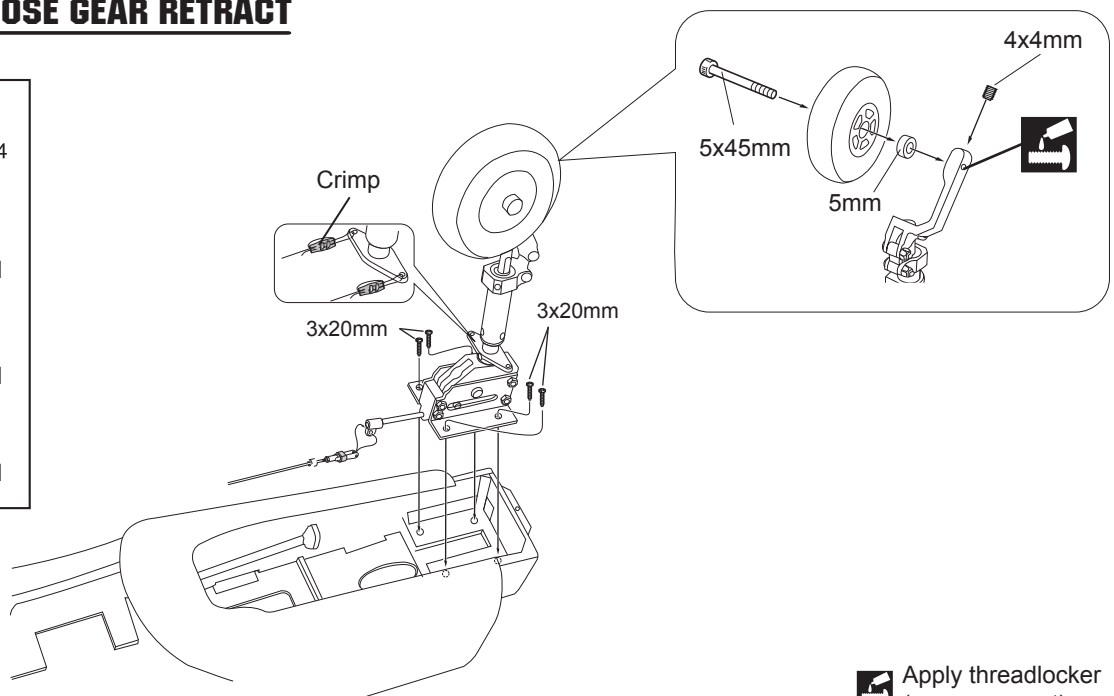
- 3 x 20mm TP Screw 4
- 5 x 45mm Cap Screw 1
- 5mm Collar 1
- 4x4mm Set Screw 1



Apply threadlocker (screw cement).

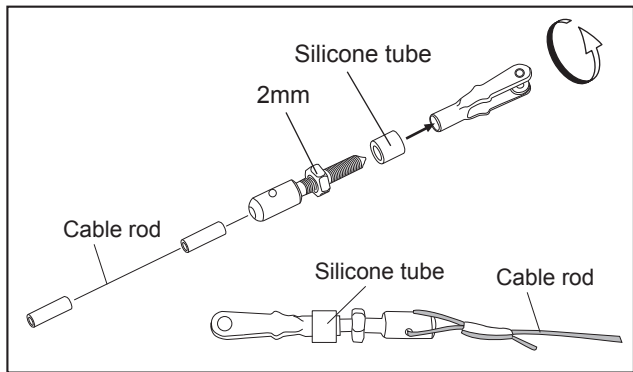
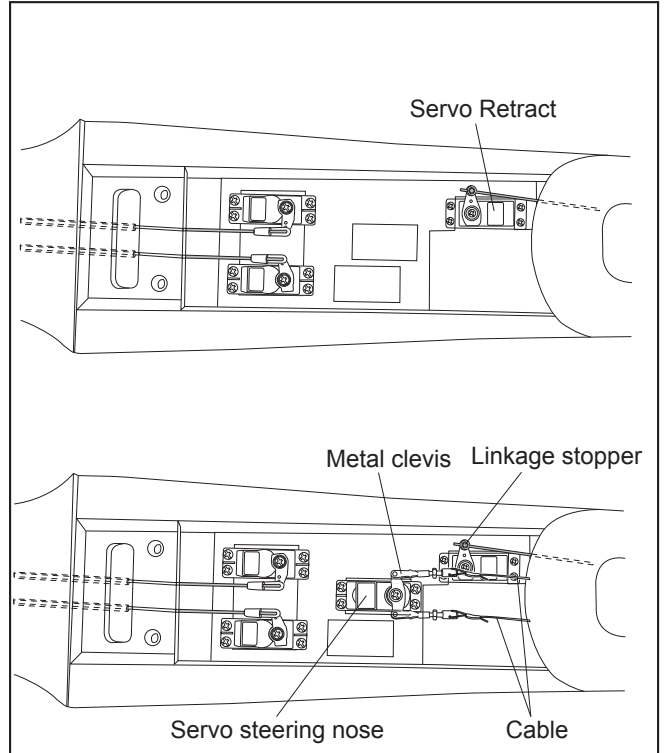
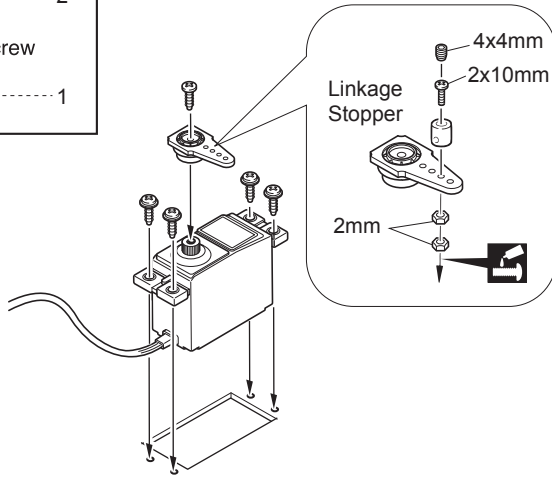

- Linkage Stopper  1
- 2mm Nut  2
- 2 x 10mm Screw  1

- 4 x 4mm Set Screw  1



 Apply threadlocker (screw cement).

INSTALLING THE ENGINE MOUNT

- 4 x 25mm Cap Screw  4
- 4mm Washer  4
- 4mm Spring Washer  4

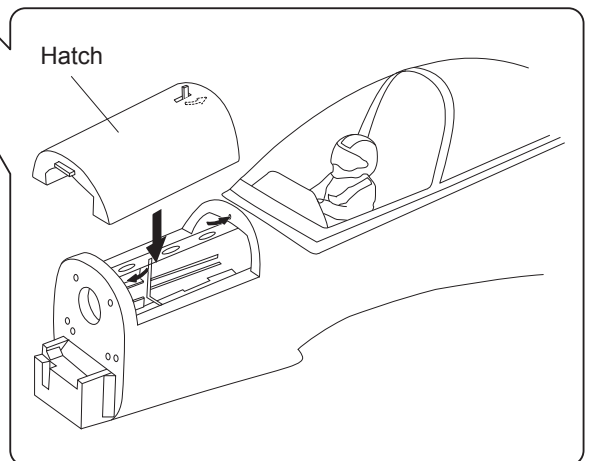
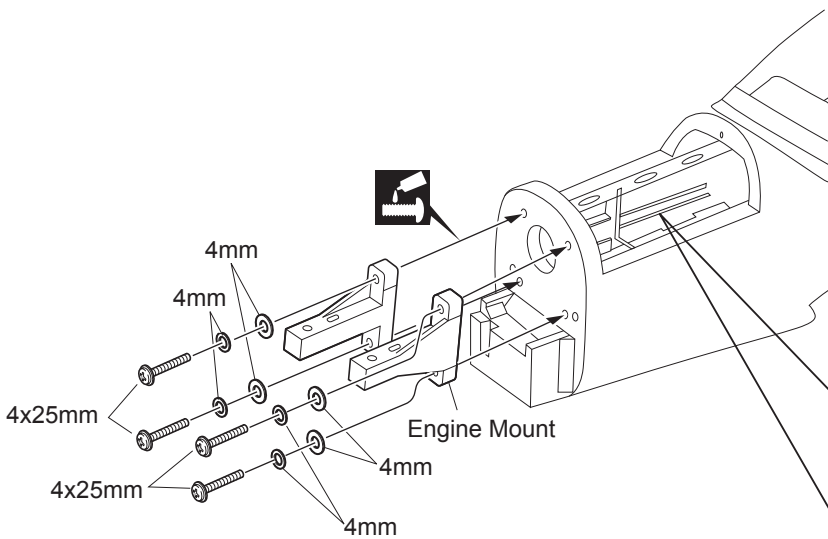

 Apply threadlocker (screw cement).

INSTALLING THE FUEL TANK

1. The stopper has been pre-assembled at the factory.
2. Using a modeling knife, cut one length of silicon fuel line (the length of silicon fuel line is calculated by how the weighted clunk should rest about 5mm away from the rear of the tank and move freely inside the tank). Connect one end of the line to the weighted clunk and the other end to the nylon pick up tube in the stopper.
3. Carefully bend the second nylon tube up at a 45 degree angle (using a cigarette lighter). This tube will be the vent tube to the muffler.
4. Carefully bend the third nylon tube down at a 45 degree angle (using a cigarette lighter). This tube will be vent tube to the fueling valve.

 *When the stopper assembly is installed in the tank, the top of the vent tube should rest just below the top surface of the tank. It should not touch the top of the tank.*

5. Test fit the stopper assembly into the tank. It may be necessary to remove some of the flashing around the tank opening using a modeling knife. If flashing is present, make sure none of it falls into the tank.

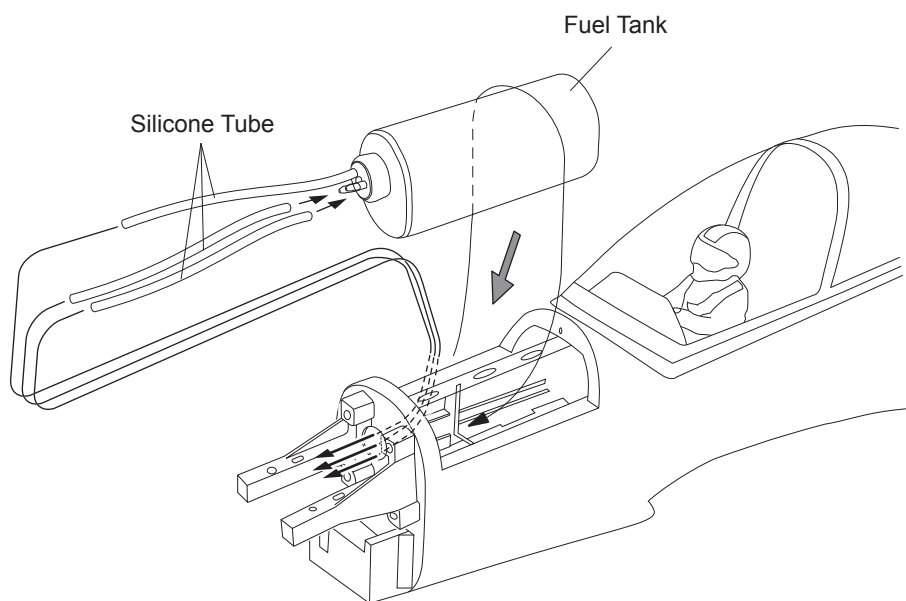

6. When satisfied with the alignment of the stopper assembly tighten the 3mm x 20mm machine screw until the rubber stopper expands and seals the tank opening. Do not over tighten the assembly as this could cause the tank to split.
7. Using a modeling knife, cut 3 lengths of fuel line 150mm long. Connect 2 lines to the 2 vent tubes and 1 line to the fuel pickup tube in the stopper.
8. Feed three lines through the fuel tank compartment and through the pre-drilled hole in the firewall. Pull the lines out from behind the engine, while guiding the fuel tank into place. Push the fuel tank as far forward as possible, the front of the tank should just about touch the back of the firewall.

Blow through one of the lines to ensure the fuel lines have not become kinked inside the fuel tank compartment. Air should flow through easily.

 *Do not secure the tank into place permanently until after balancing the airplane. You may need to remove the tank to mount the battery in the fuel tank compartment.*

9. Secure the fuel tank.

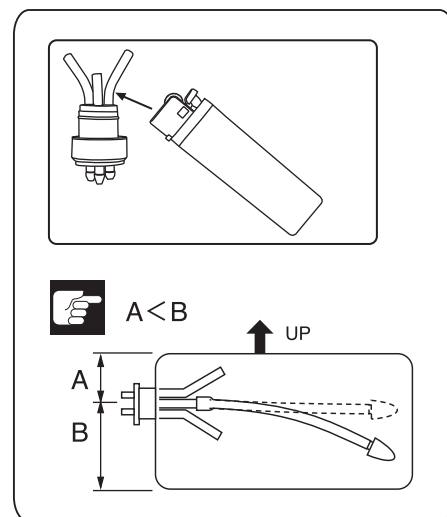

INSTALLING THE THROTTLE PUSHROD SERVO

1. Place the engine into the engine mount and align it properly with the front of the cowling.

 *If your engine is equipped with a remote needle valve, we suggest installing it into the engine at this time.*

2. Slide the pushrod housing through the hole in the firewall, through the hole in the forward bulkhead, and into the servo compartment.

3. Apply epoxy glue to the pushrod housing where it exits the firewall and where it passes through the forward bulkhead. This will secure the housing in place.
4. Using a modeling knife, cut off the nylon pushrod housing 26mm in front of the servo tray.

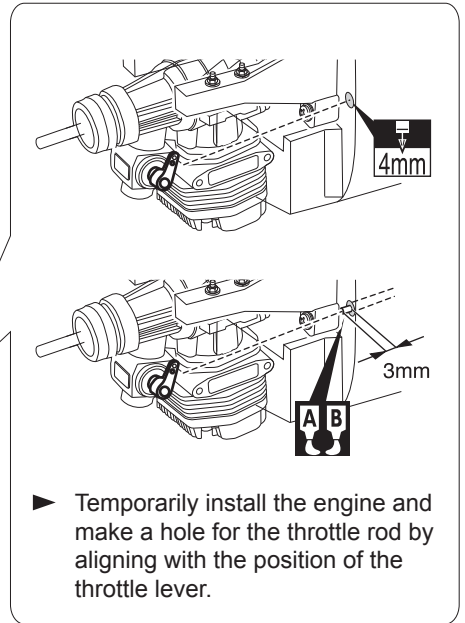
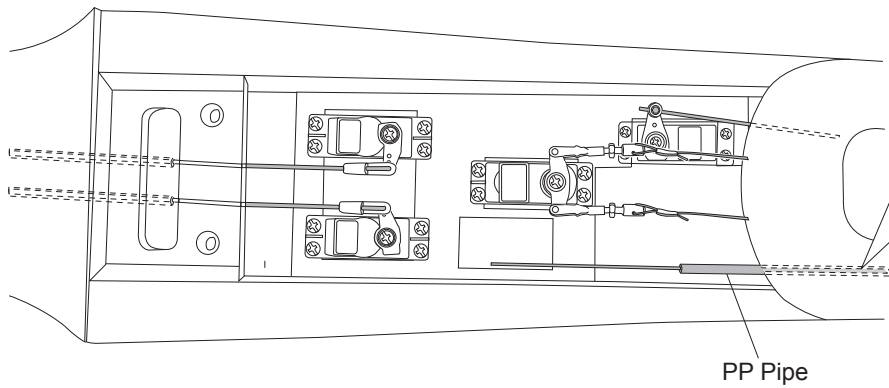

► Temporarily install the engine and make a hole for the throttle rod by aligning with the position of the throttle lever.

INSTALLING THE ENGINE

Locate the long piece of wire used for the throttle pushrod. One end of the wire has been pre-bend in to a "Z" bend at the factory. This "Z" bend should be inserted into the throttle arm of the engine when the engine is fitted onto the engine mount. Fit the engine to the engine mount using the screws provided.

3 x 25mm Cap Screw	4
3mm Nut	4
3mm Washer	4

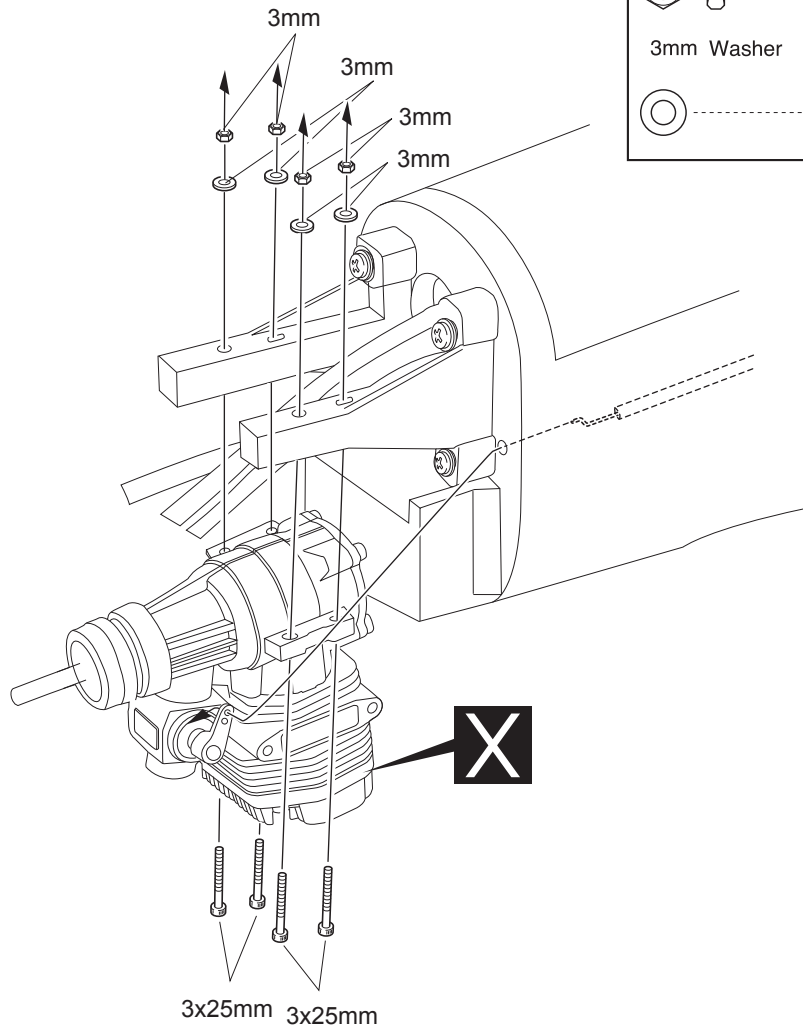
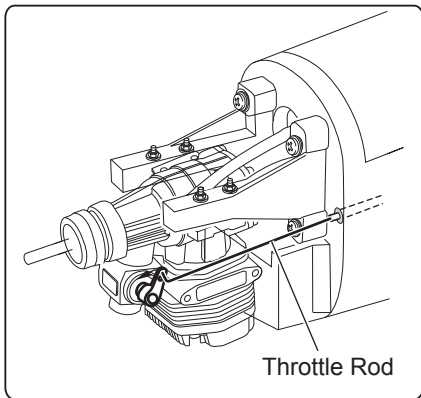

X Must be purchased separately!

INSTALLING THE THROTTLE

1. Install one adjustable metal connector through the third hole out from the center of one servo arm, enlarge the hole in the servo arm using a 2mm drill bit to accommodate the servo connector. Remove the excess material from the arm.

! After installing the adjustable metal connector apply a small drop of thin C/A to the bottom nut. This will prevent the connector from loosening during flight.

2. Plug the throttle servo into the receiver and turn on the radio system. Check to ensure that the throttle servo output shaft is moving in the correct direction. When the throttle stick is moved forward from idle to full throttle, the throttle barrel should also open and close using this motion. If not, reverse the direction of the servo, using the transmitter.

3. Slide the adjustable metal connector / servo arm assembly over the plain end of the pushrod wire. Position the throttle stick and the throttle trim at their lowest positions.
4. Manually push the carburetor barrel fully closed. Angle the arm back about 45 degree from center and attach the servo arm onto the servo. With the carburetor barrel fully closed, tighten the set screw in the adjustable metal connector.
5. Remove the excess throttle pushrod wire using wire cutters and install the servo arm retaining screw.

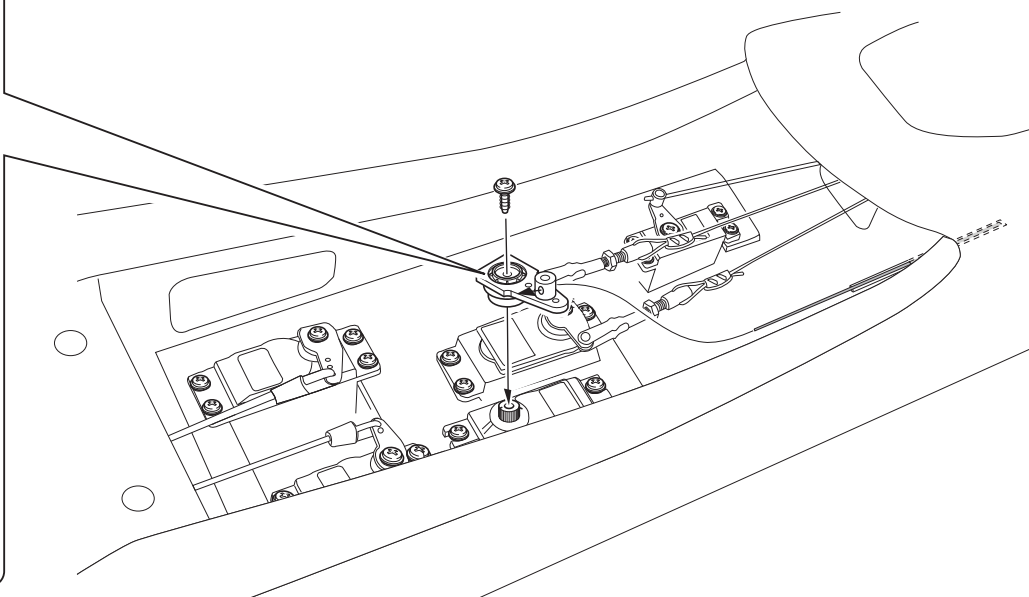
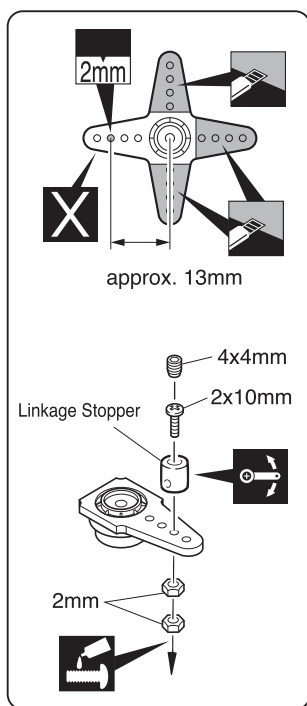
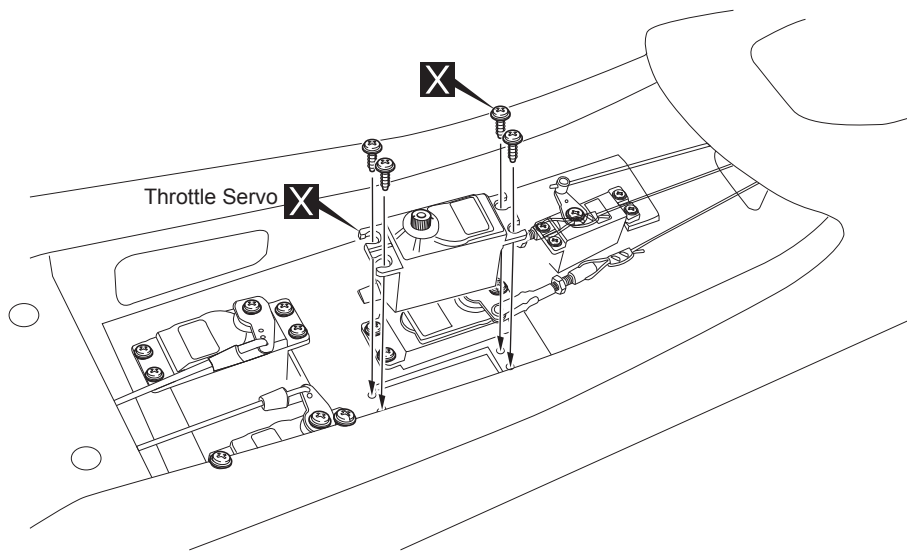

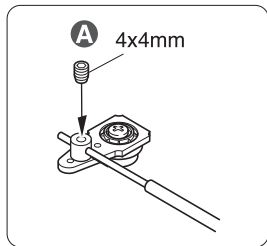
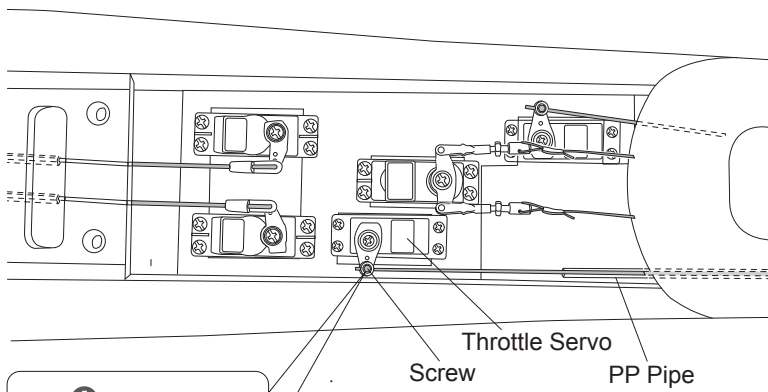

A Adjust the throttle input (transmitter throttle stick), throttle trim movement and the carburetor opening to the suitable position and screw in the 4x4mm set screw.

- Cut off shaded portion
- Must be purchased separately!
- Apply threadlocker (screw cement).
- Ensure smooth, non-binding movement when assembling

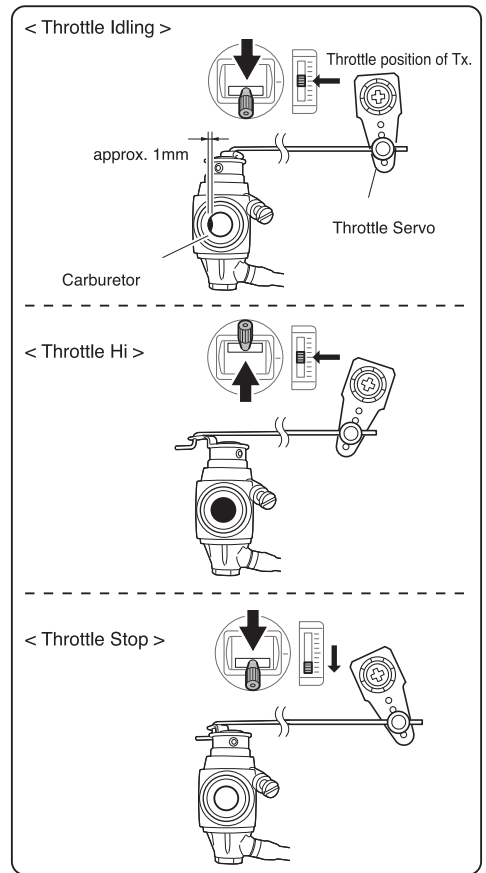

MOUNTING THE COWL

1. Remove the muffler and needle valve assembly from the engine. Slide the fiberglass cowl over the engine.
2. Measure and mark the locations to be cut out for engine head clearance, needle valve, muffler. Remove the cowl and make these cutouts using a rotary tool with a cutting disc and a rotary sanding drum attachment.
3. Slide the cowl back into place. Align the front of the cowl with the crankshaft of the engine. The front of the cowl should be positioned so the crankshaft is in the middle of the precut opening. Hold the cowl firmly in place using several pieces of masking tape.
4. While holding the cowl firmly in position, drill four 1,6mm pilot holes through both the cowl and the side edges of the firewall.
5. Using a 3mm drill bit, enlarge the four holes in the cowling.

Enlarging the holes through the cowl will prevent the fiberglass from splitting when the mounting screws are installed.

6. Slide the cowl back over the engine and secure it in place using four screws.
7. Install the muffler. Connect the fuel and pressure lines to the carburetor, muffler and fuel filler valve. Tighten the screws completely.

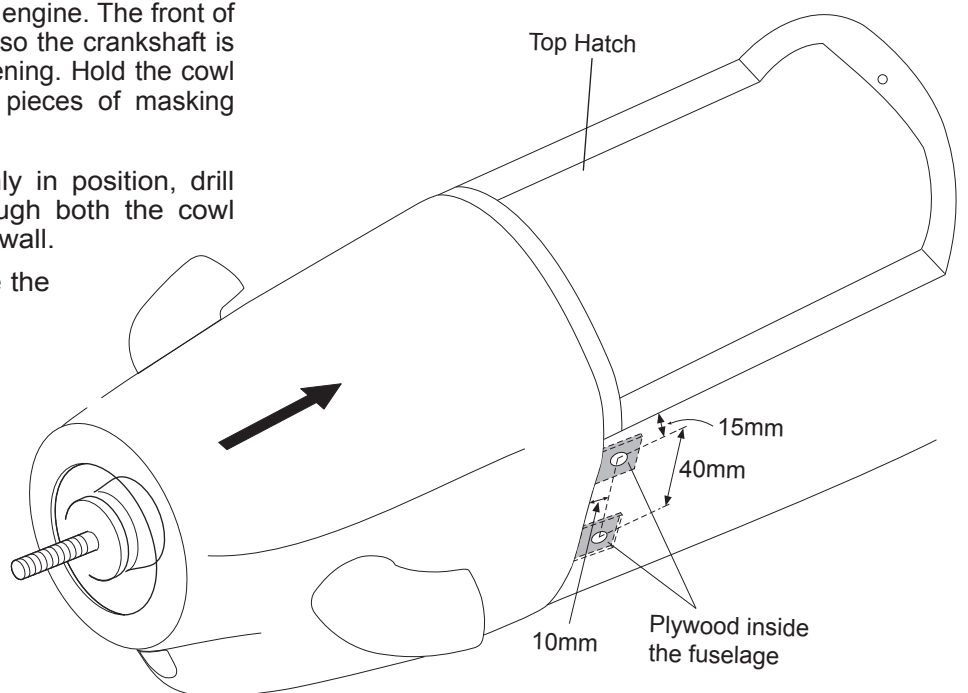

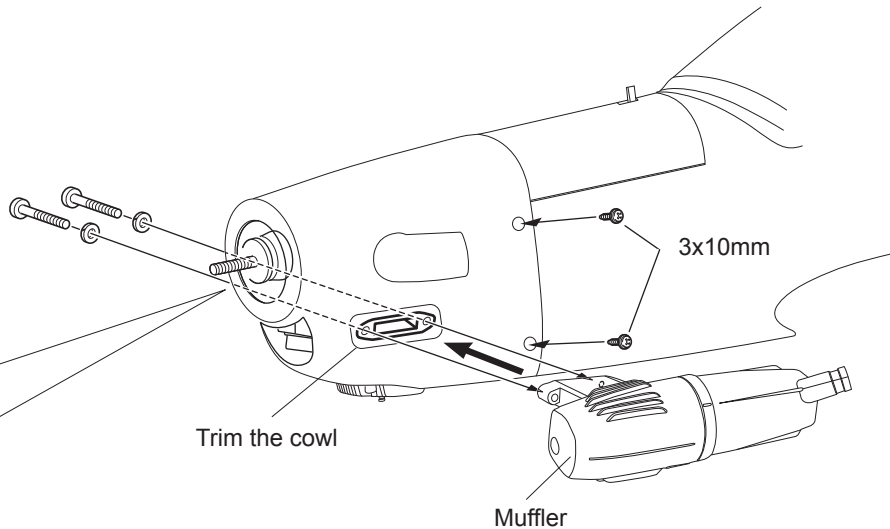
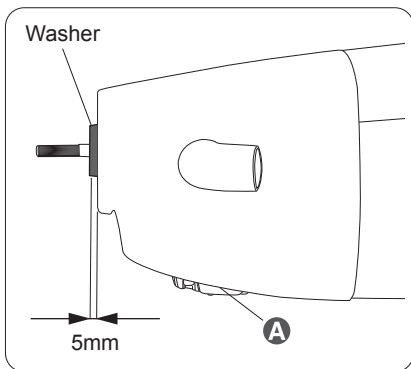
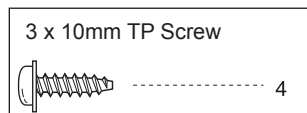

A Trim the cowling so it will match your engine

INSTALLING THE SPINNER

Install the spinner back-plate, propeller and spinner cone. The spinner cone is held in place using two screws.

! *The propeller should not touch any part of the spinner cone. If it does, use a sharp modeling knife and carefully trim away the spinner cone where the propeller comes in contact with it.*

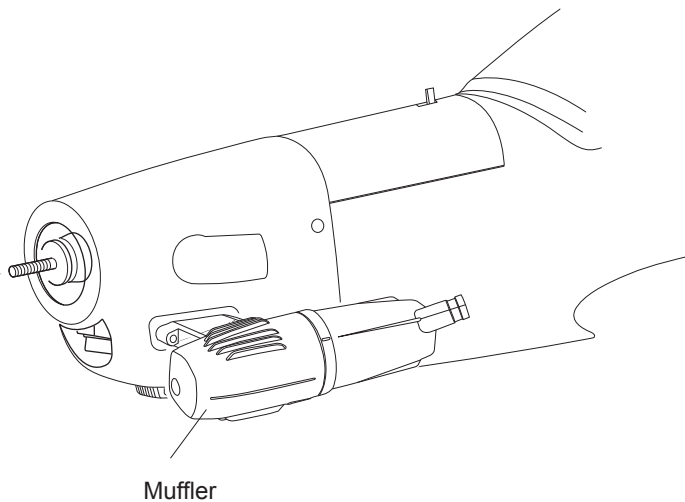
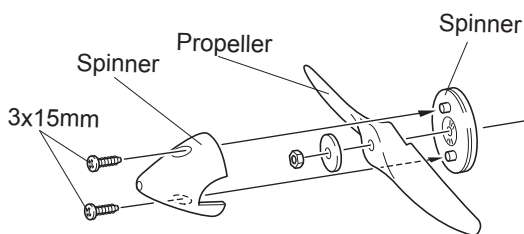
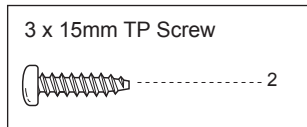

INSTALLING THE RECEIVER AND BATTERY

1. Plug the servo leads and the switch lead into the receiver. You may want to plug an aileron extension into the receiver to make plugging in the aileron servo lead easier when you are installing the wing. Plug the battery pack lead into the switch.
2. Wrap the receiver and battery pack in the protective foam to protect them from vibration. Use a rubber band or masking tape to hold the foam in place.

! *Do not permanently secure the receiver and battery until after balancing the model.*

INSTALLING THE SWITCH

1. The switch should be mounted on the fuselage side, opposite the muffler, close enough to the receiver so the lead will reach. Use the face plate of the switch cut out and locate the mounting holes.
2. Cut out the switch hole using a modeling knife. Use a 2mm drill bit and drill out the two mounting holes through the fuselage side.
3. Secure the switch in place using the two machine screws provided with the radio system.

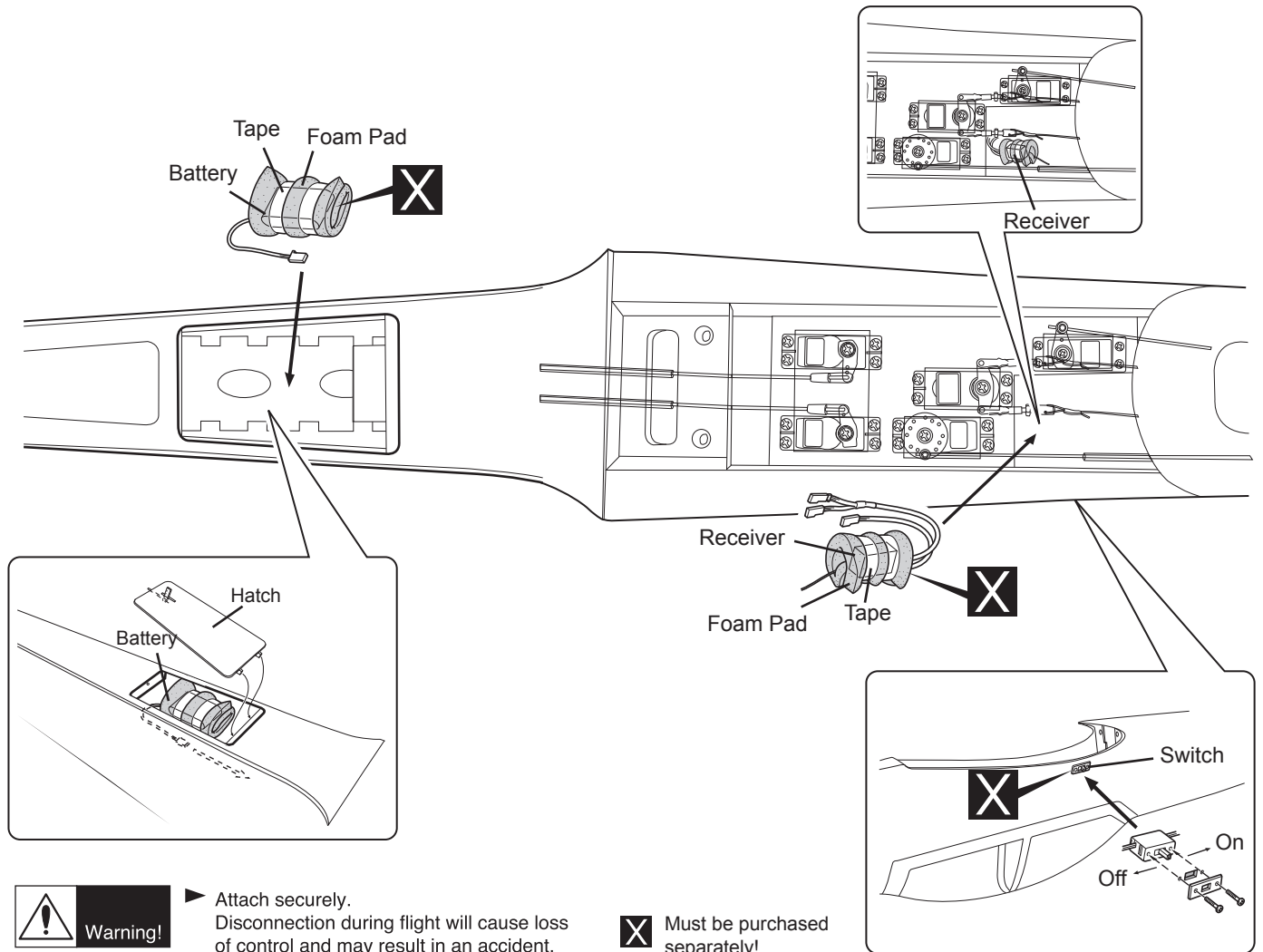

INSTALLING THE ELECTRIC MOTOR

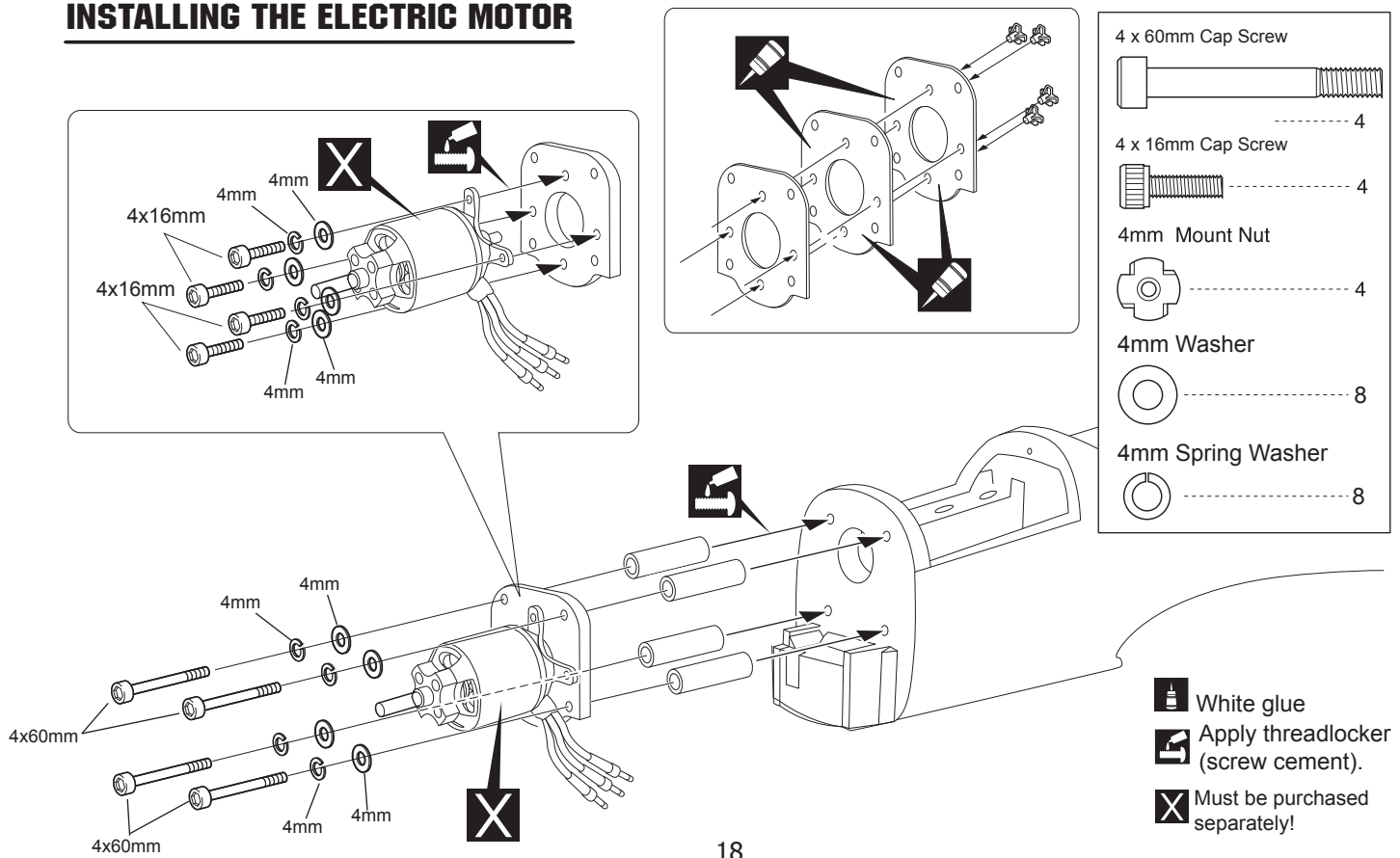

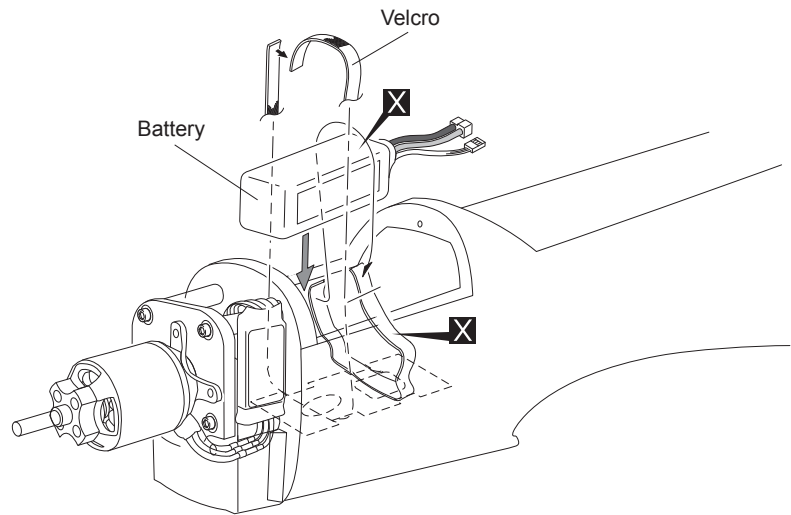
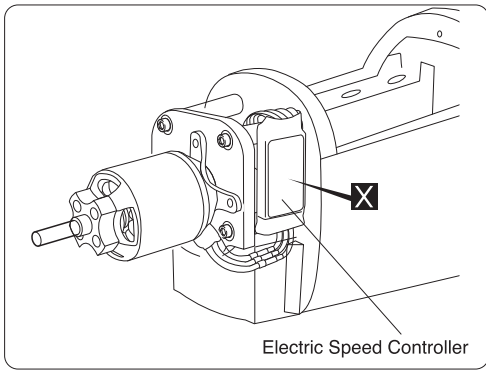

X Must be purchased separately!

Follow instruction manual of Motor and ESC.

< Check the motor rotation >

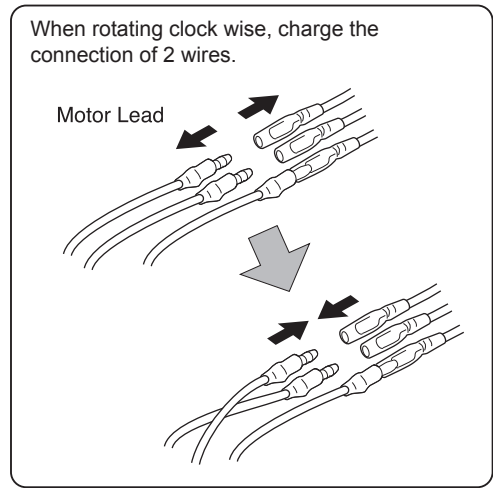
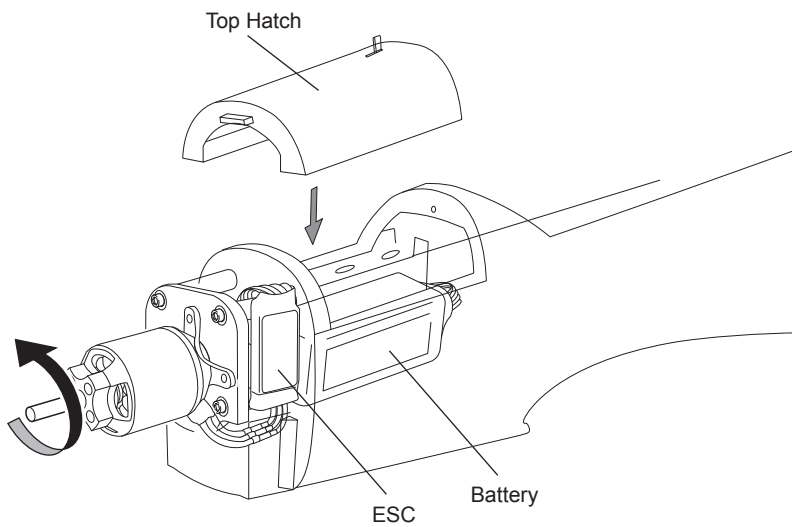

BALANCING

1. It is critical that your airplane be balanced correctly. Improper balance will cause your plane to lose control and crash.

THE CENTER OF GRAVITY IS LOCATED 90-100mm (3.5-3.9 in) BACK FROM THE LEADING EDGE OF THE WING, AT THE FUSELAGE. BALANCE A PLANE UPSIDE DOWN WITH THE FUEL TANK EMPTY.

2. Mount the wing to the fuselage. Using a couple of pieces of masking tape, place them on the top side of the wing 90-100mm (3.5-3.9 in) back from the leading edge, at the fuselage sides.

3. Turn the airplane upside down. Place your fingers on the masking tape and carefully lift the plane.

4. If the nose of the plane falls, the plane is nose heavy. To correct this first move the battery pack further back in the fuselage. If this is not possible or does not correct it, stick small amounts of lead weight on the fuselage under the horizontal stabilizer. If the tail of the plane falls, the plane is tail heavy. To correct this, move the battery and receiver forward or if this is not possible, stick weight into the firewall. When balanced correctly, the airplane should sit level or slightly nose down when you lift it up with your fingers.

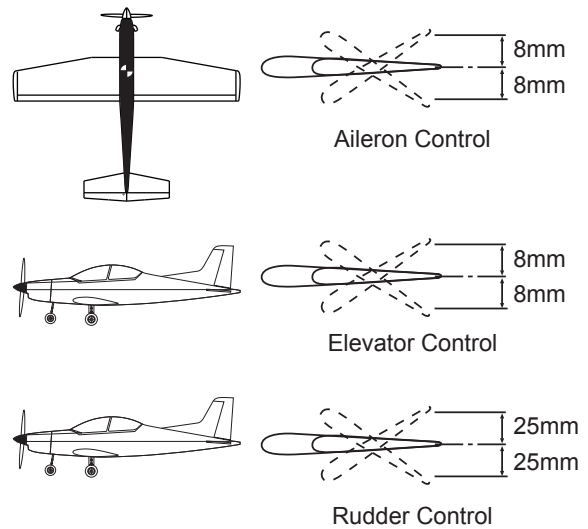
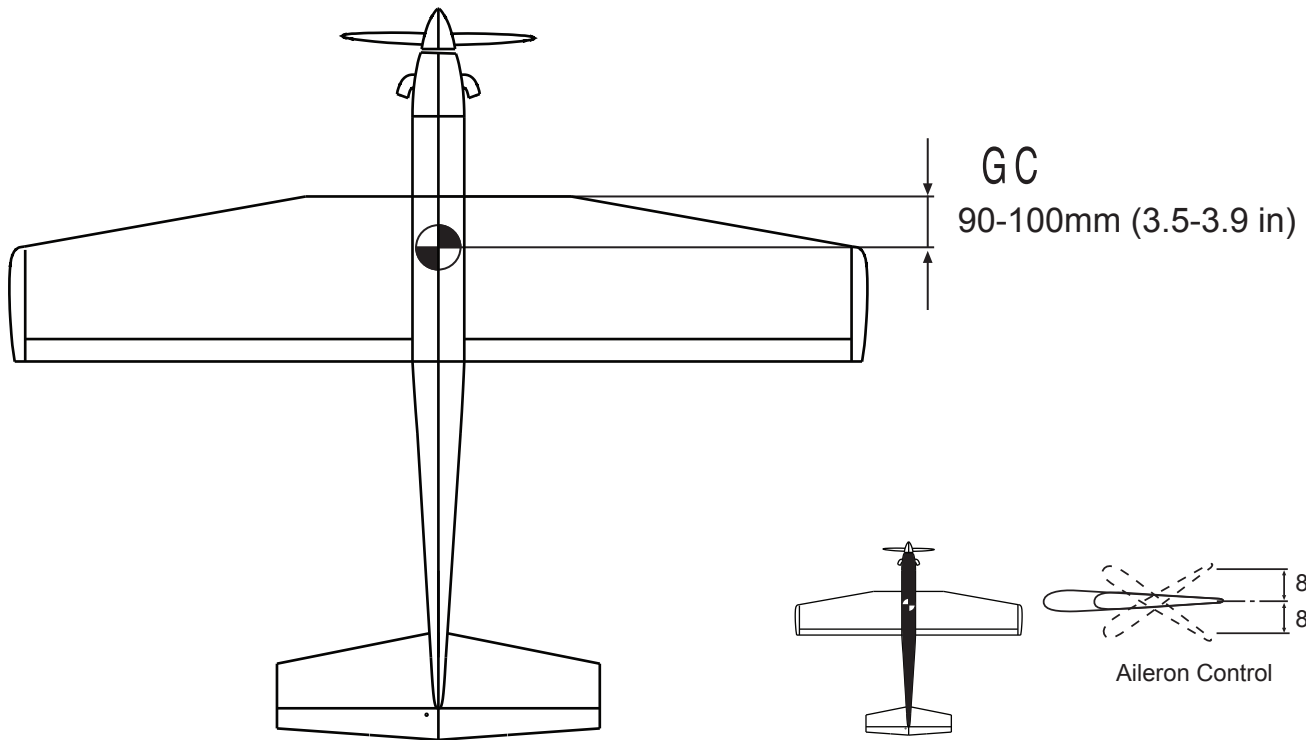

LATERAL BALANCE

! After you have balanced a plane on the C.G. You should laterally balance it. Doing this will help the airplane track straighter.

5. Turn the airplane upside down. Attach one loop of heavy string to the engine crankshaft and one to the tail wheel wire. With the wings level, carefully lift the airplane by the string. This may require two people to make it easier.
6. If one side of the wing fall, that side is heavier than the opposite. Add small amounts of lead weight to the bottom side of the lighter wing half's wing tip. Follow this procedure until the wing stays level when you lift the airplane.

CONTROL THROWS

1. We highly recommend setting up a plane using the control throws listed.
2. The control throws should be measured at the widest point of each control surface.
3. Check to be sure the control surfaces move in the correct directions.

Ailerons : 8mm up 8mm down
 Elevator : 8mm up 8mm down
 Rudder : 25mm right 25mm left

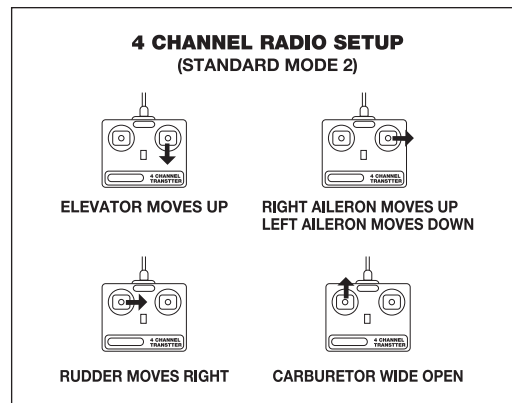

FLIGHT PREPARATION

PRE FLIGHT CHECK

1. Completely charge your transmitter and receiver batteries before your first day of flying.
2. Check every bolt and every glue joint in your plane to ensure that everything is tight and well bonded.
3. Double check the balance of the airplane
4. Check the control surface
5. Check the receiver antenna . It should be fully extended and not coiled up inside the fuselage.
6. Properly balance the propeller.

**FOR YOUR RADIO INSTALLATION
BASIC CONNECTION FOR AIRPLANE AND ADJUSTMENT OF SERVO**

Example of connection

- For more information, refer to radio system instruction manual.
- Follow instruction manual of Engine and Battery.

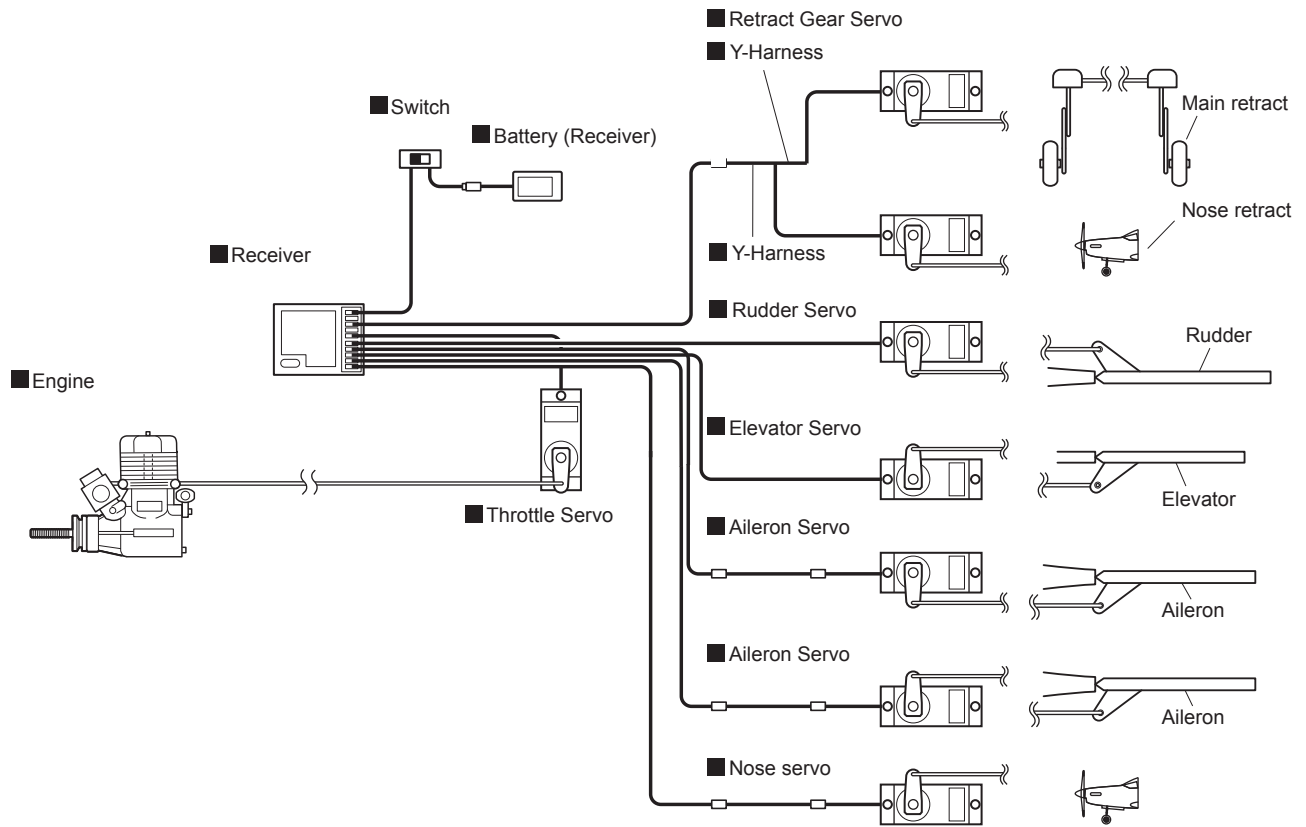

Main Gear Dimensional Detail

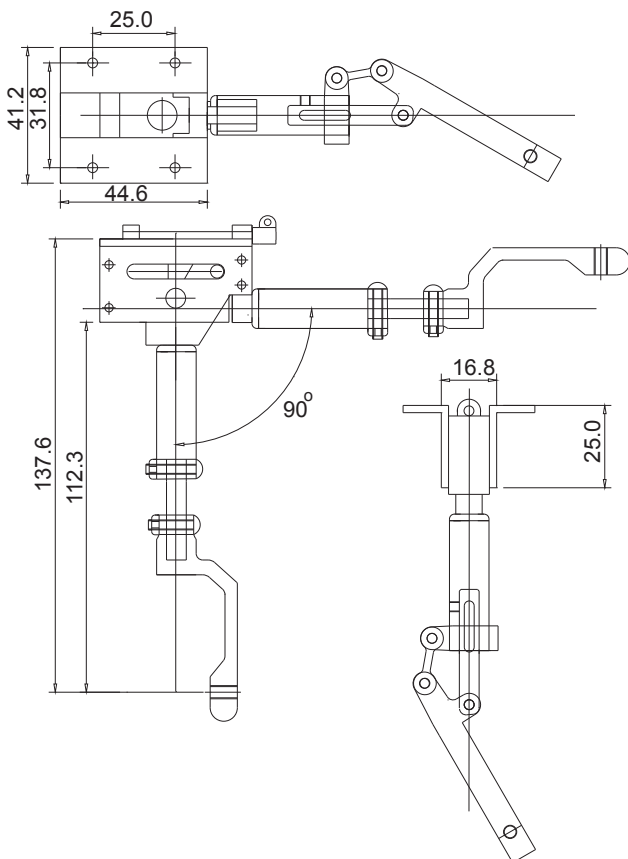

Nose Gear Dimensional Detail

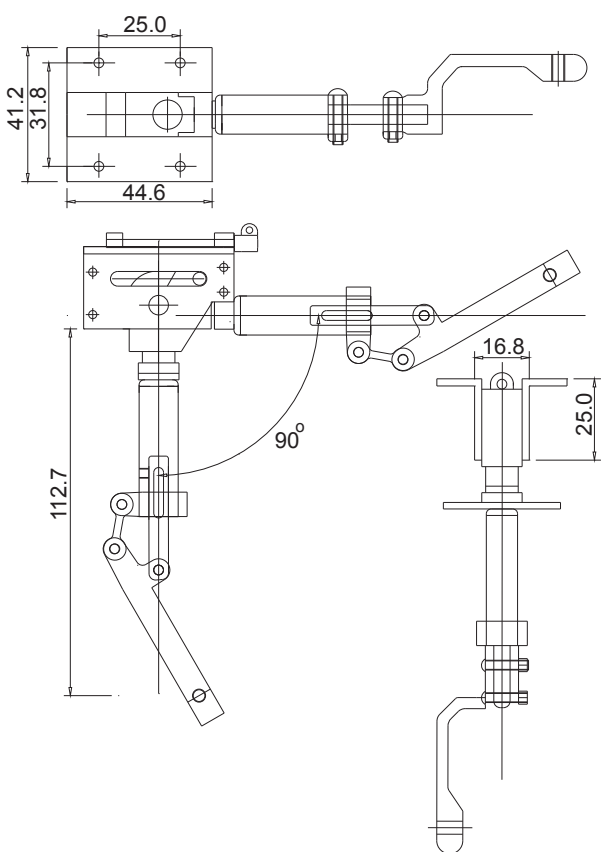

EXPLODED VIEW

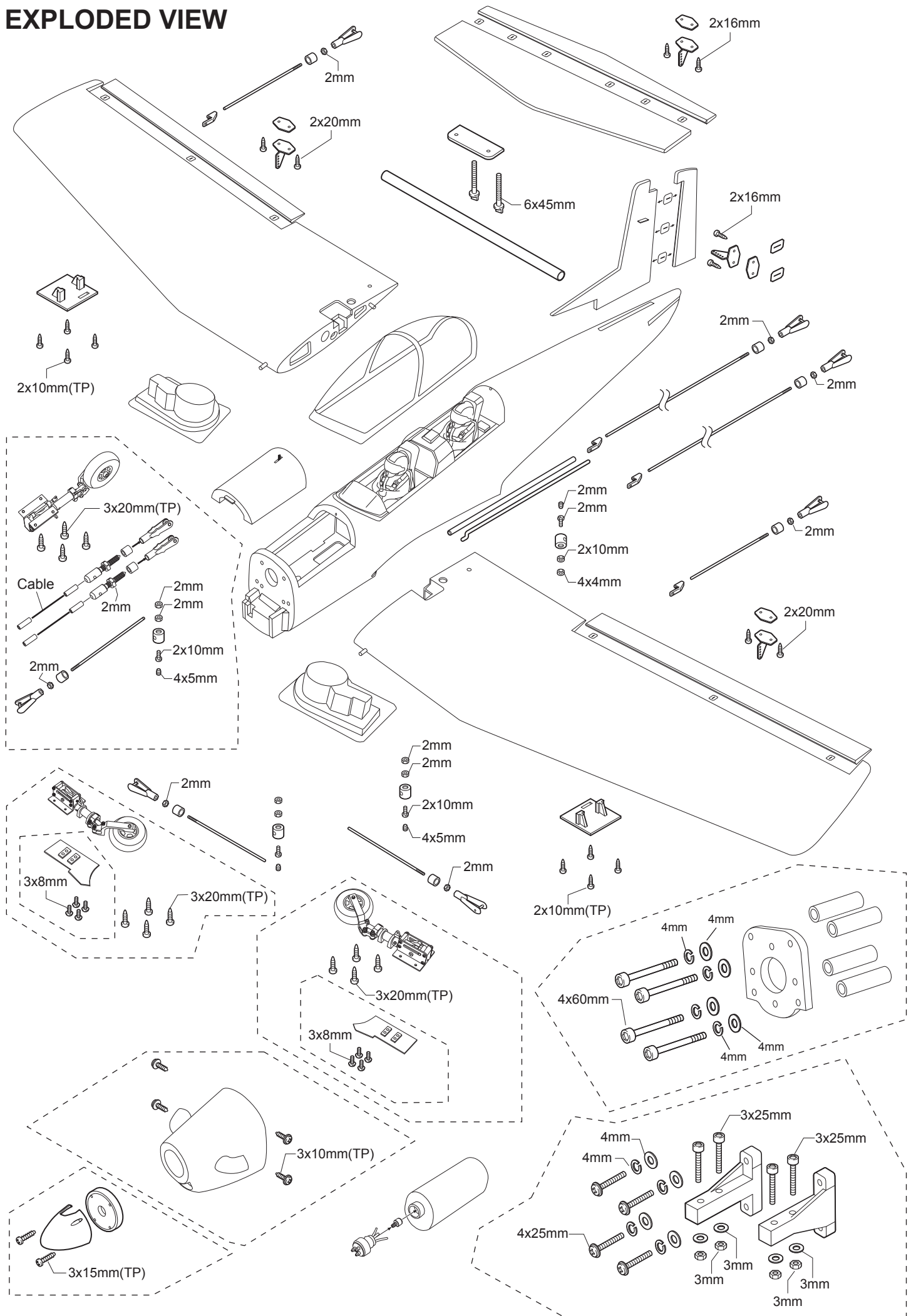

I/C FLIGHT GUIDELINES

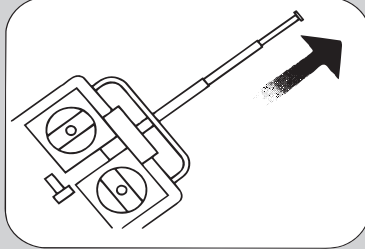

When ready to fly, first extend the transmitter aerial.

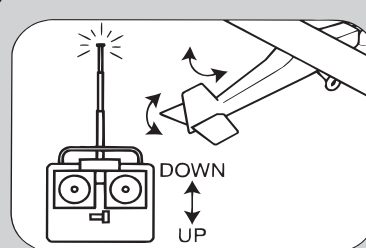

Operate the control sticks on the transmitter and check that the control surfaces move freely and in the CORRECT directions.

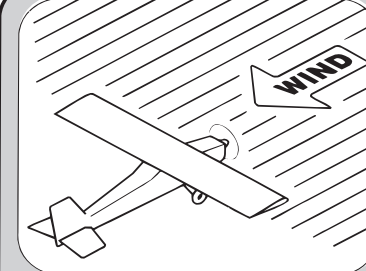

ALWAYS land the model INTO the wind, this ensures that the model lands at the slowest possible speed.

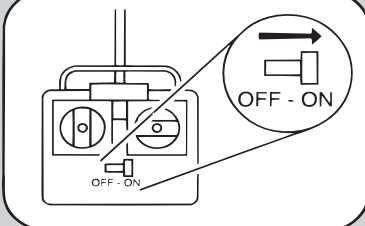

Switch on the transmitter.

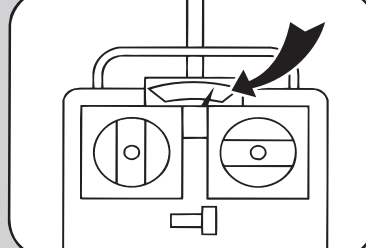

Check that the transmitter batteries have adequate power.

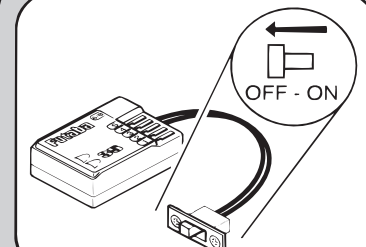

Switch off the receiver.

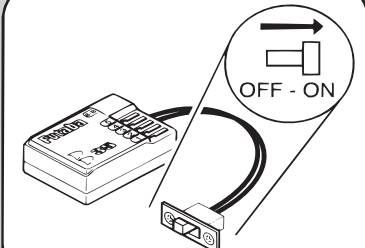

Switch on the receiver.



ALWAYS take off into the wind.

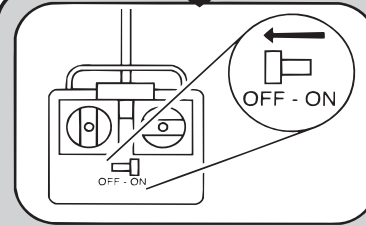

Switch off the transmitter.

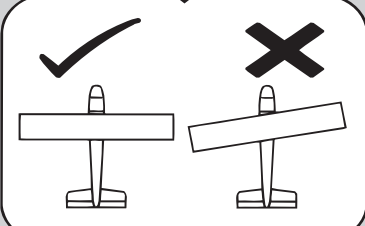

Check that the wings are correctly fitted to the fuselage.

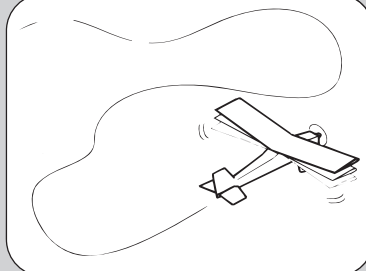

If the model does not respond correctly to the controls, land it as soon as possible and correct the fault.

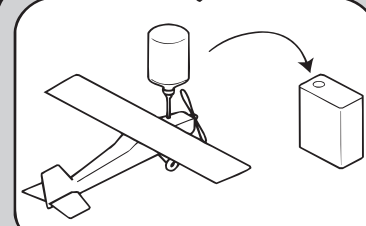

Empty the fuel tank after flying, fuel left in the tank can cause corrosion and lead to engine problems.